



# Component LED



## HOLDER & LAMP PLUG-IN COMPONENTS

- Indicator
- Signboard
- IoT server
- Home appliance
- RJ45 Indicator



光鼎電子股份有限公司

PARA LIGHT ELECTRONICS CO., LTD

11F, No. 8, Jiankang Rd., Zhonghe Dist., New Taipei City 23586, Taiwan

+886-2-2225-3733

para@para.com.tw

www.para.com.tw



INNOVATE  
COOPERATION  
INTEGRITY  
EVELOPMENT

Chairman Mr. David Ma  
Capital USD 37 million  
No. of Employee 676

## OUR HISTORY

PARA LIGHT was founded in 1987, and listed on Taiwan Stock Exchange (TWSE) in 2008 (ticker number 6226).

PARA LIGHT is now one of the global leaders in LED Design and Manufacturing. 9 years ago, PARA LIGHT established the first OPTICAL LAB, by which PARA LIGHT is able to provide Optical Solutions, and also expands our services to LED MODULE Design and Manufacturing.

PARA LIGHT's manufacturing facilities are located in China (Nanjing and Lianyungan), and Myanmar (Yangon), certified with ISO 14001, ISO 9001, and IATF 16949. PARA LIGHT produces high quality products complied to REACH and RoHS standard.

Sales offices are based in Taiwan, China, USA and India. Our sales team and certified distributors are located around the world to provide immediate services and prompt delivery to the customers.

Adhering to the enterprise philosophy of "customer first, service quality, creativity reality, skillfulness technique has always been the mission statement at the Para Light Electronics.

# CATALOG

## Lamp Series

3mm Series	07
5mm Series	12
8mm Series	17
Rectangle Series	18
Tapping Series	21

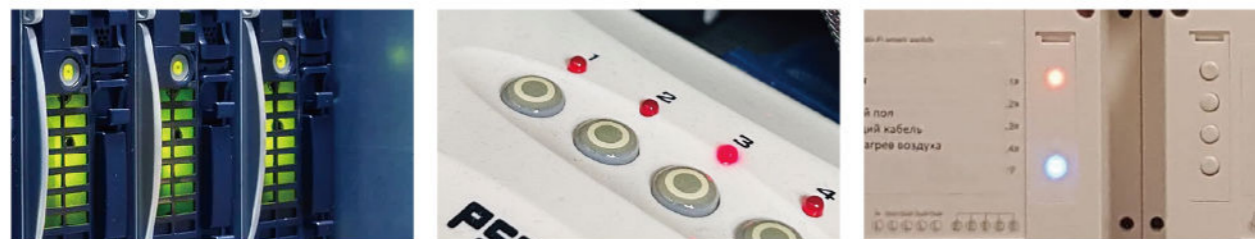

# CATALOG

## Holder Series

Single Level	25
Dual Level	28
Tri Level	29
Four Level	30
Multiple Series	31



# Lamp Series Applications

- ◆ Indicator
- ◆ Signboard
- ◆ IoT server
- ◆ Home appliance
- ◆ RJ45 Indicator



## L204 (Single Color) Dimension 1.8 mm

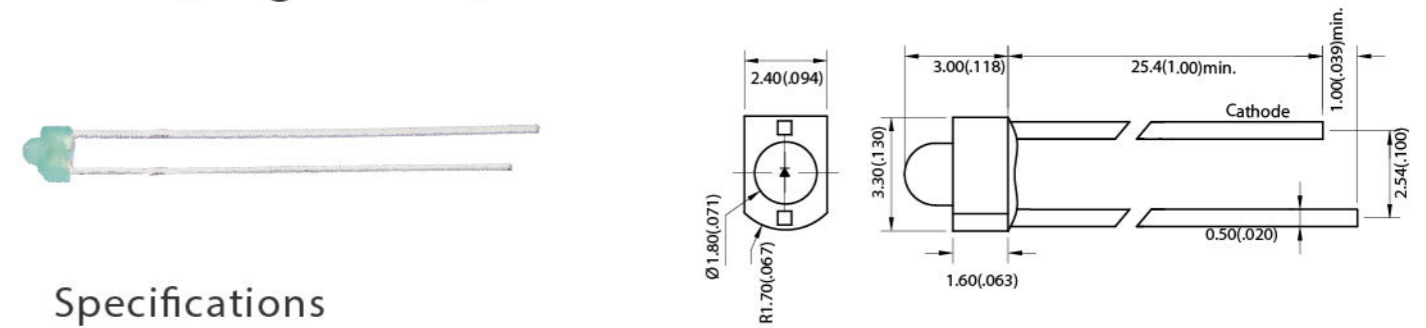

### Specifications

Series	Ref. PN	Color	Wavelength $\lambda_d$ (nm)/ CIE (x,y)	Resin Type	Typ. Luminous Intensity $I_v$ (mcd)	Viewing Angle (deg.)	Typ. Forward Voltage $V_F$ (V)	Forward Current $I_F$ (mA)
L204G	LOR2GD078G	Yellow Green	570	Green Diffused	15	60	1.9	20
L204Y	LWR2YD206G	Yellow	589	Yellow Diffused	85	70	2.1	
L204SR	LVR2SRD006G	Hyper Red	645	Red Diffused	100	60	1.9	
L204LPG6	LRR2LPG6D117G	Green	522	Green Diffused	3000	100	3.0	

## L304 (Single Color) Dimension 3 mm

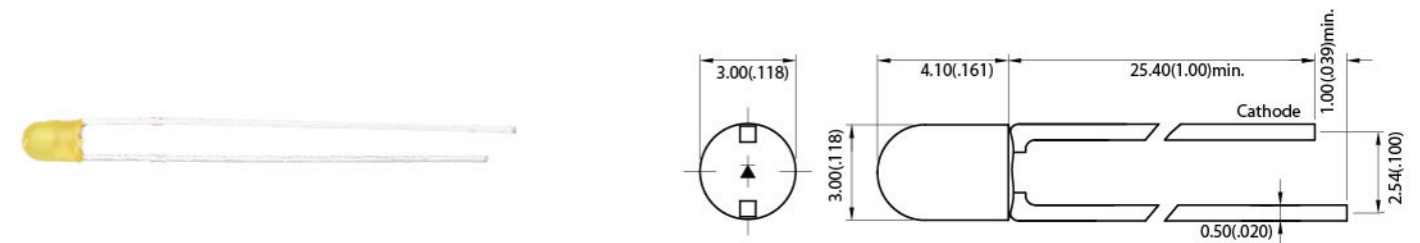

### Specifications

Series	Ref. PN	Color	Wavelength $\lambda_d$ (nm)/ CIE (x,y)	Resin Type	Typ. Luminous Intensity $I_v$ (mcd)	Viewing Angle (deg.)	Typ. Forward Voltage $V_F$ (V)	Forward Current $I_F$ (mA)
L304G	LQR3GD333G	Yellow Green	570	Green Diffused	18	110	1.9	20
L304Y	LXR3YD088G	Yellow	590	Yellow Diffused	22	175		
L304E	LQR3ED334G	Super Red	622	Red Diffused	25	110	3.0	
L304UB5	LQR3UB5D313G	Blue	462	Blue Diffused	240	100		

L314 (Single Color) Dimension 3 mm

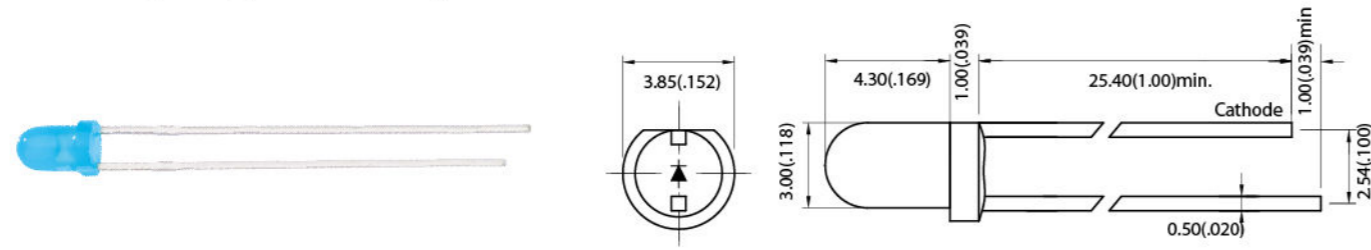

Specifications

Series	Ref. PN	Color	Wavelength $\lambda_d$ (nm)/ CIE (x,y)	Resin Type	Typ. Luminous Intensity $I_v$ (mcd)	Viewing Angle (deg.)	Typ. Forward Voltage $V_F$ (V)	Forward Current $I_F$ (mA)
L314G	LLR3GD334G	Yellow Green	570	Green Diffused	20	60	1.9	20
L314E	LLR3ED199G	Super Red	630	Red Diffused	20			
L314SR	LRR3SRC176G	Hyper Red	640	Water Clear	115	60	3.0	20
L314UB5	LRR3UB5D224G	Blue	470	Blue Diffused	600			
L314UW5	LOR3UW5C090G	White	(0.29, 0.30)	Water Clear	7000	20	3.1	

L354 (Single Color) Dimension 3 mm

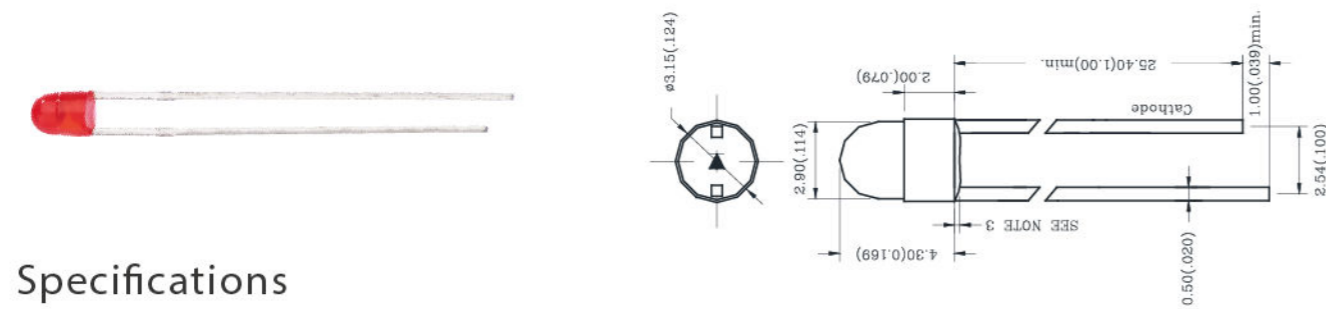

Specifications

Series	Ref. PN	Color	Wavelength $\lambda_d$ (nm)/ CIE (x,y)	Resin Type	Typ. Luminous Intensity $I_v$ (mcd)	Viewing Angle (deg.)	Typ. Forward Voltage $V_F$ (V)	Forward Current $I_F$ (mA)
L354G	LPR3GD217G	Yellow Green	570	Green Diffused	20	60	1.9	20
L354Y	LXR3YD009G	Yellow	589	Yellow Diffused	28	170	2.1	
L354E	LVR3ED009G	Red	622	Red Diffused	40	60	1.9	20
L354UB5	LKR3UB5D008G	Blue	470	Blue Diffused	450		3.0	
L354LPG6	LVR3LPG6C010G	Green	525	Water Clear	4000	40	3.2	
L354UW5	LVR3UW5W011G	White	(0.30, 0.30)	White Diffused	800	80	3.0	

L3U4 (Single Color) Dimension 3 mm

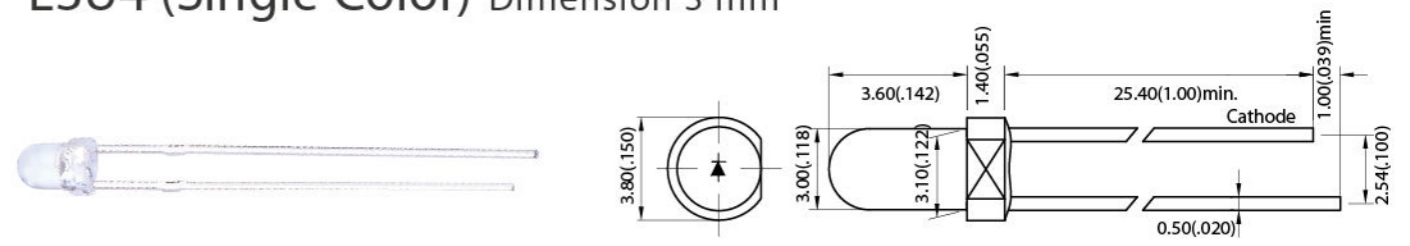

Specifications

Series	Ref. PN	Color	Wavelength $\lambda_d$ (nm)/ CIE (x,y)	Resin Type	Typ. Luminous Intensity $I_v$ (mcd)	Viewing Angle (deg.)	Typ. Forward Voltage $V_F$ (V)	Forward Current $I_F$ (mA)
L3U4G	LOR3GD071G	Yellow Green	570	Green Diffused	20	60	1.9	20
L3U4E	LVR3ED016G	Super Red	622	Red Diffused	25			
L3U4SR	LQR3SRD320G	Hyper Red	638	Red Diffused	50	60	3.0	20
L3U4UB5	LQR3UB5D292G	Blue	466	Blue Diffused	80			
L3U4LPG6	LJR3LPG6C290	Green	525	Water Clear	4500	25	3.0	
L3U4UW5	LUR3UW5W097GA	White	(0.30, 0.32)	White Diffused	3200	30	2.8	

L334 (Single Color) Dimension 3 mm

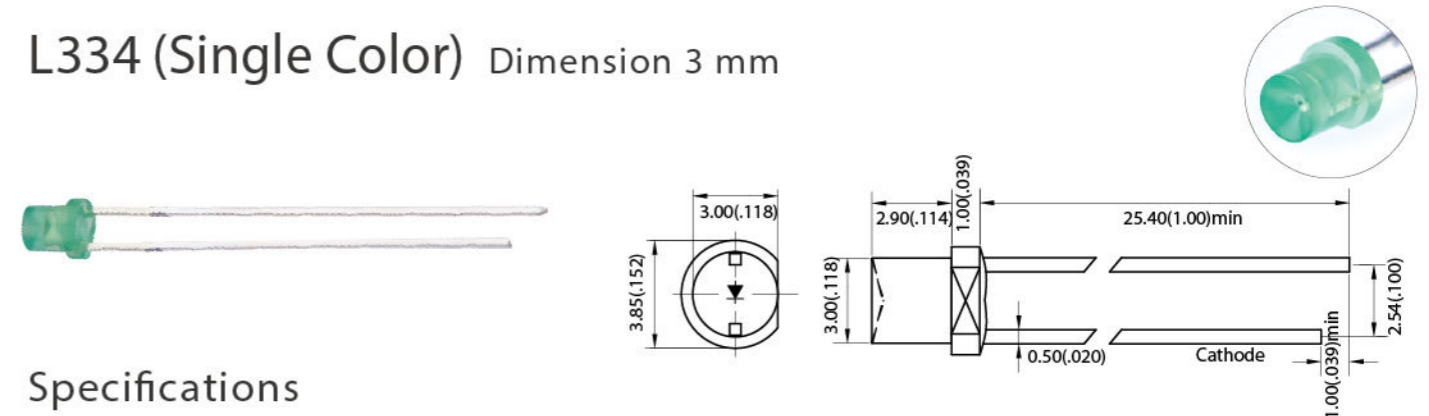

Specifications

Series	Ref. PN	Color	Wavelength $\lambda_d$ (nm)/ CIE (x,y)	Resin Type	Typ. Luminous Intensity $I_v$ (mcd)	Viewing Angle (deg.)	Typ. Forward Voltage $V_F$ (V)	Forward Current $I_F$ (mA)
L334G	LJR3GD332	Yellow Green	570	Green Diffused	12	150	1.9	20
L334Y	LJR3VY5C251	Yellow	590		300	120	1.9	
L334E	LUR3VEXC070G	Super Red	620	Water Clear	250	150	2.1	20
L334UB5	LNR3UB5C012G	Blue	470		280	120	3.0	
L334LPG6	LVR3LPG6C029G	Green	520		600	115	3.0	
L334UW5	LQR3UW5C288G	White	(0.27, 0.25)		290	130	3.2	

L3N4 (Single Color) Dimension 3 mm

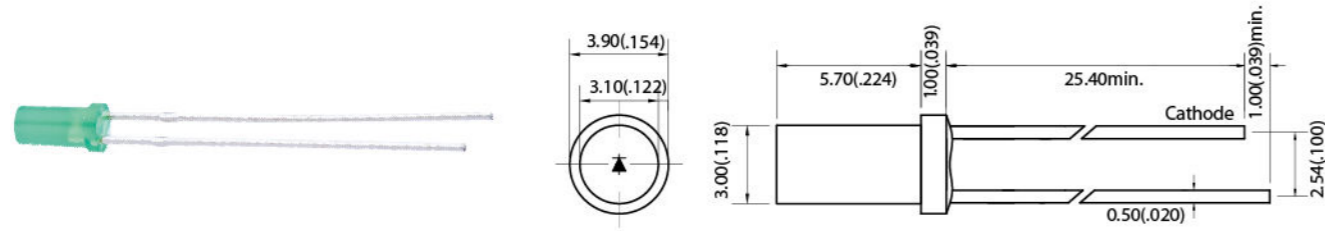

Specifications

Series	Ref. PN	Color	Wavelength $\lambda_d$ (nm)/ CIE (x,y)	Resin Type	Typ. Luminous Intensity $I_v$ (mcd)	Viewing Angle (deg.)	Typ. Forward Voltage $V_F$ (V)	Forward Current $I_F$ (mA)
L3N4G	LNR3GD137G	Yellow Green	570	Green Diffused	6	150	1.9	20
L3N4Y	LWR3YD033G	Yellow	588	Yellow Diffused	20	160	1.9	
L3N4SR	LPR3SRC053G	Hyper Red	636	Water Clear	55	40	2.1	
L3N4UB5	LLR3UB5D012G	Blue	465	Blue Diffused	360	150	3.0	
L3N4LPG6	LWR3LPG6D127G	Green	520	Green Diffused	520	150	2.9	

L6V4 (Single Color) Dimension 3 mm

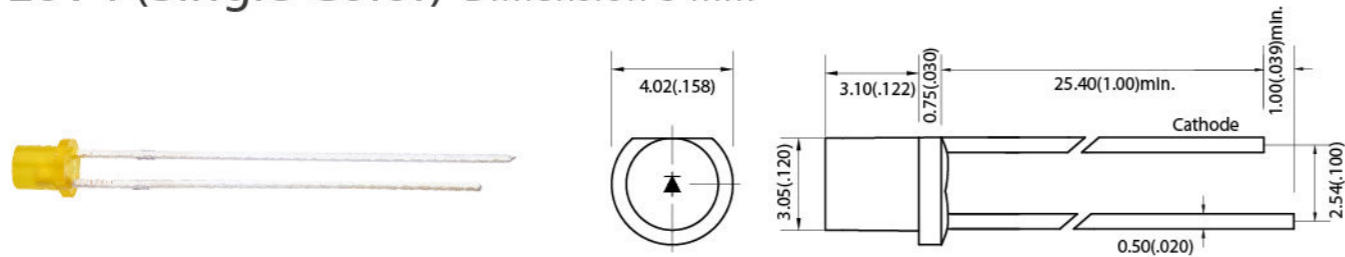

Specifications

Series	Ref. PN	Color	Wavelength $\lambda_d$ (nm)/ CIE (x,y)	Resin Type	Typ. Luminous Intensity $I_v$ (mcd)	Viewing Angle (deg.)	Typ. Forward Voltage $V_F$ (V)	Forward Current $I_F$ (mA)
L6V4G	LLR3VG3T207G	Yellow Green	570	Green Transparent	50	110	2.1	20
L6V4Y	LQR3LY4C037G	Yellow	590	Water Clear	160	140	1.9	
L6V4E	LQR3LESC038G	Red	620	Water Clear	150	150	2.0	
L6V4UB5	LRR3UB5D219G	Blue	465	Blue Diffused	220	110	3.0	
L6V4UW5	LQR3UW5C036G	White	(0.27,0.26)	Water Clear	700	140	3.0	

L317 (Dual Color) Dimension 3 mm

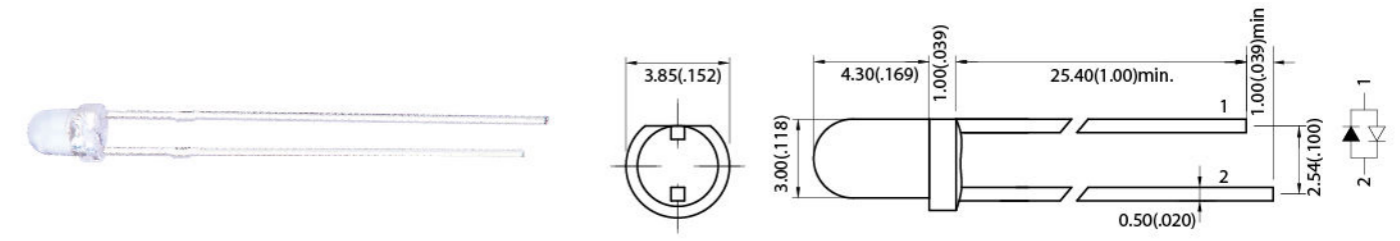

Specifications

Series	Ref. PN	Color	Wavelength $\lambda_d$ (nm)/ CIE (x,y)	Resin Type	Typ. Luminous Intensity $I_v$ (mcd)	Viewing Angle (deg.)	Typ. Forward Voltage $V_F$ (V)	Forward Current $I_F$ (mA)
L317EG	LJR3EGW010	Super Red Yellow Green	622 570	White Diffused	90 50	40	1.9	20
L317SRG	LOR3SRVG3W006G	Hyper Red Yellow Green	640 570		20 18	110	1.9	
L317UB5R	LHR3UB5HURW251	Blue Red	470 633		750 200	60	3.0 2.0	

L319 (Dual Color) Dimension 3 mm

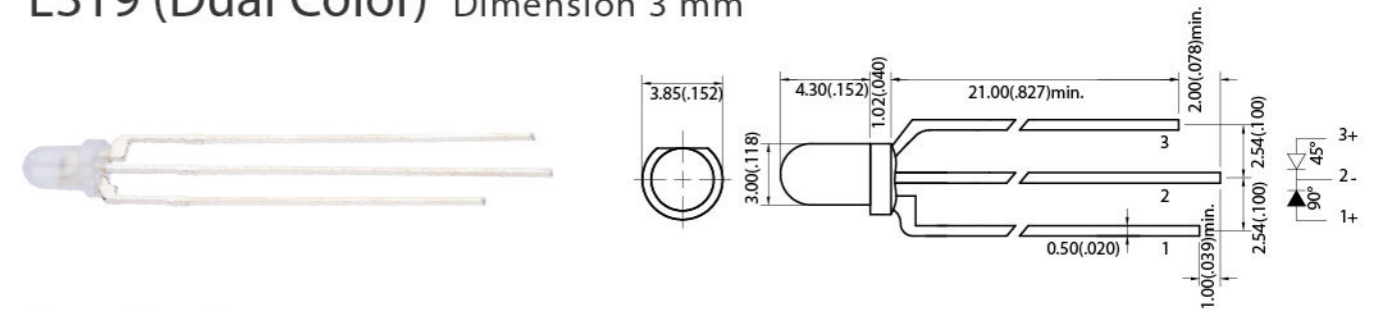

Specifications

Series	Ref. PN	Color	Wavelength $\lambda_d$ (nm)/ CIE (x,y)	Resin Type	Typ. Luminous Intensity $I_v$ (mcd)	Viewing Angle (deg.)	Typ. Forward Voltage $V_F$ (V)	Forward Current $I_F$ (mA)
L319YG	LLR8LY1VG3W303G	Yellow Yellow Green	590 570	White Diffused	110 100	60	2.1 2.0	20
L319LESG	LLR3LESGW048G	Orange Yellow Green	605 571		120 10	130	2.0 2.2	
L319RG	LSR3HURVG3W076G	Red Yellow Green	620 572		140 35	60	1.9 1.9	
L319RLPG6	LTR3HURLPG6C292G	Super Red Green	629 530	Water Clear	150 2000	80	1.8 2.6	5

## L523 (Single Color)

Dimension 5 mm

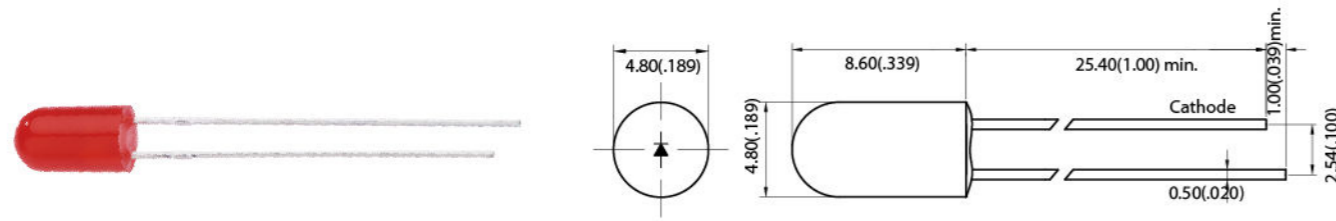

## Specifications

Series	Ref. PN	Color	Wavelength $\lambda_d$ (nm)/ CIE (x,y)	Resin Type	Typ. Luminous Intensity $I_v$ (mcd)	Viewing Angle (deg.)	Typ. Forward Voltage $V_F$ (V)	Forward Current $I_F$ (mA)
L523G	LZR5VG3D034Y	Yellow Green	570	Green Diffused	45	65	1.9	
L523Y	LXR5VYXW004G	Yellow	589	White Diffused	7000	45	2.0	
L523VE	LZR5VED033Y	Super Red	621	Red Diffused	800	35	1.9	20
L523UB5	LMR5UB5W165GA	Blue	465	White Diffused	700	60	3.1	
L523LPG6	LVR5LPG6C112G	Green	522	Water Clear	21000	25	2.9	

## L5T47 (Single Color)

Dimension 5 mm

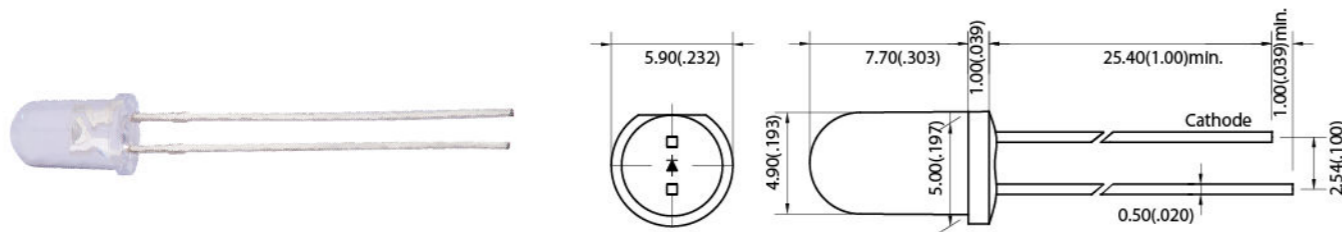

## Specifications

Series	Ref. PN	Color	Wavelength $\lambda_d$ (nm)/ CIE (x,y)	Resin Type	Typ. Luminous Intensity $I_v$ (mcd)	Viewing Angle (deg.)	Typ. Forward Voltage $V_F$ (V)	Forward Current $I_F$ (mA)
L5T47VEA	LLR5VEAC183G	Red	621		5600	40	2.0	
L5T47VYX	LVR5VYXC080G	Yellow	591		7800	30	2.1	
L5T47UB5	LQR5UB5C084G	Blue	465	Water Clear	4000	20	3.0	20
L5T47LPG6	LQR5LPG6C422G	Green	530		7000	30	2.9	
L5T47UW5	LOR5UW5C039G	White	(0.29, 0.30)		4000	30	3.0	

## L503 (Single Color) Dimension 5 mm

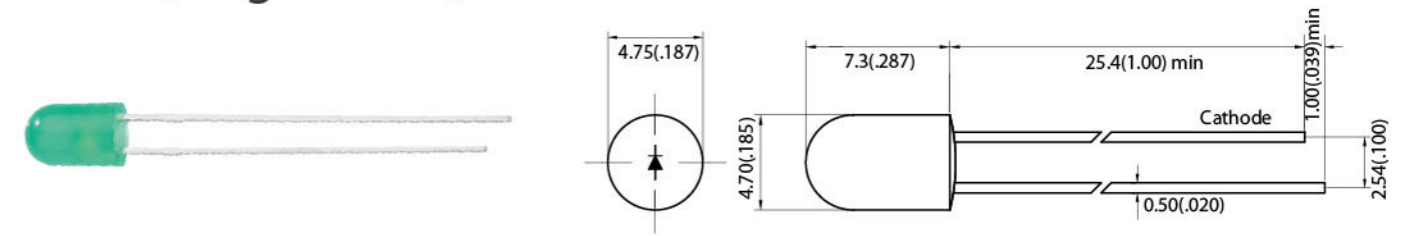

## Specifications

Series	Ref. PN	Color	Wavelength $\lambda_d$ (nm)/ CIE (x,y)	Resin Type	Typ. Luminous Intensity $I_v$ (mcd)	Viewing Angle (deg.)	Typ. Forward Voltage $V_F$ (V)	Forward Current $I_F$ (mA)
L503G	LVR5GD041G	Yellow Green	570	Green Diffused	20			
L503E	LVR5ED040G	Super Red	622	Red Diffused	25	110	2.0	20
L503Y	LSR5VYAC079GA	Yellow	587	Water Clear	1300	30	2.1	

## L513 (Single Color) Dimension 5 mm

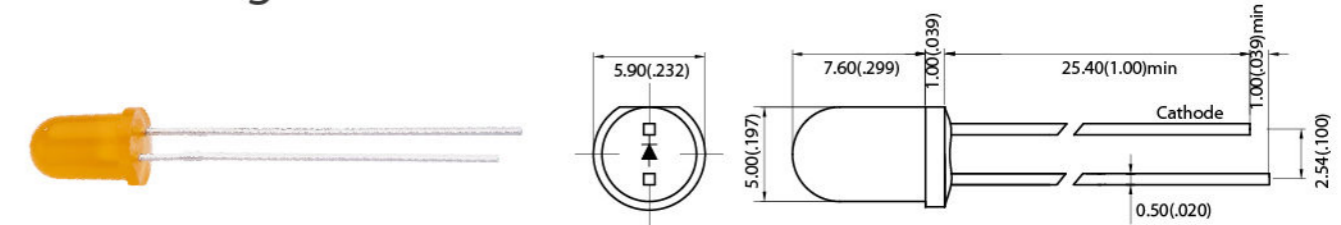

## Specifications

Series	Ref. PN	Color	Wavelength $\lambda_d$ (nm)/ CIE (x,y)	Resin Type	Typ. Luminous Intensity $I_v$ (mcd)	Viewing Angle (deg.)	Typ. Forward Voltage $V_F$ (V)	Forward Current $I_F$ (mA)
L513G	LMR5GD188G	Yellow Green	570	Green Diffused	80	120		
L513Y	LMR5YD205G	Yellow	589	Yellow Diffused	50	110	1.9	
L513E	LLR5ED221G	Super Red	622	Red Diffused	10	110		20
L513UB5	LSR5UB5C094G	Blue	464		9000	10		
L513LPG6	LOR5LPG6C119G	Green	525	Water Clear	6000	25	3	
L513UW5	LOR5UW5C039G	White	(0.29, 0.30)		4000	30		

### L5P47 (Single Color) Dimension 5 mm

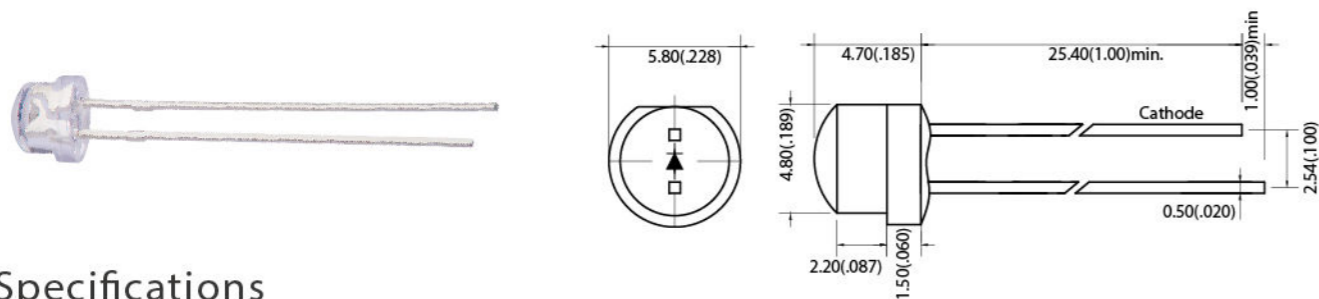

#### Specifications

Series	Ref. PN	Color	Wavelength $\lambda_d$ (nm)/ CIE (x,y)	Resin Type	Typ. Luminous Intensity $I_v$ (mcd)	Viewing Angle (deg.)	Typ. Forward Voltage $V_F$ (V)	Forward Current $I_F$ (mA)
L5P47VE	LUR5VEAC112G	Red	620	Water Clear	1650	90	2.0	20
L5P47VY	LUR5VYXC034G	Yellow	590		2000	30	1.9	
L5P47UB5	LUR5UB5C101G	Blue	480		1500	60	2.9	
L5P47LPG6	LPR5LPG6C073G	Green	521		1200	75	3	
L5P47UW5	LSR5UW5C222G	White	(0.27, 0.26)		1000	90	15	

### L553 (Single Color) Dimension 5 mm

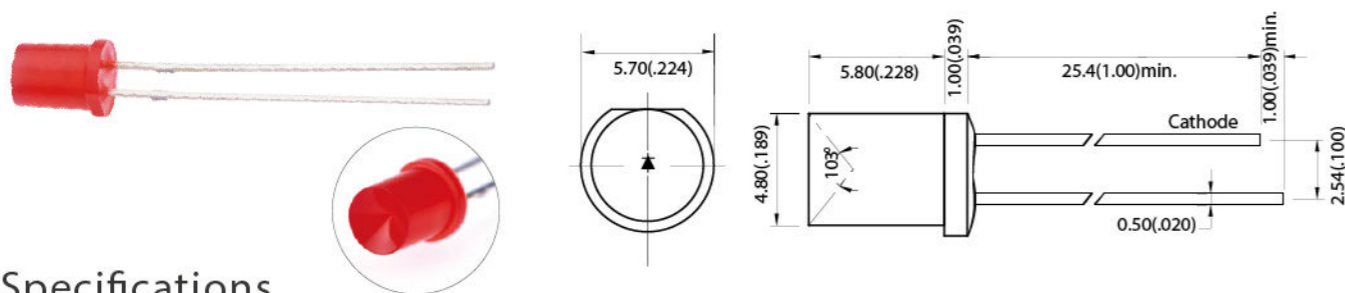

#### Specifications

Series	Ref. PN	Color	Wavelength $\lambda_d$ (nm)/ CIE (x,y)	Resin Type	Typ. Luminous Intensity $I_v$ (mcd)	Viewing Angle (deg.)	Typ. Forward Voltage $V_F$ (V)	Forward Current $I_F$ (mA)			
L553G	LPR5VG3D225G	Yellow Green	570	Green Diffused	10	110	1.9	20			
L553Y	LPR5LY1D226G	Yellow	589	Yellow Diffused							
L553E	LPR5LR1D224G	Super Red	628	Red Diffused							
L553UB5	LVR5UB5C031G	Blue	460	Water Clear					400	30	3.0
L553LPG6	LVR5LPG6C030G	Green	525						350	120	
L553UW5	LQR5UW5C285G	White	(0.27, 0.25)		180	150					

### L5N3 (Single Color) Dimension 5 mm

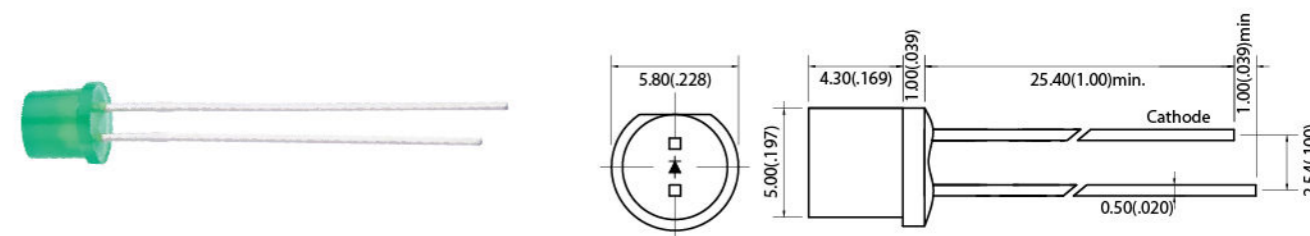

#### Specifications

Series	Ref. PN	Color	Wavelength $\lambda_d$ (nm)/ CIE (x,y)	Resin Type	Typ. Luminous Intensity $I_v$ (mcd)	Viewing Angle (deg.)	Typ. Forward Voltage $V_F$ (V)	Forward Current $I_F$ (mA)	
L5N3G	LSR5GW240G	Yellow Green	573	White Diffused	10	140	1.9	20	
L5N3Y	LQR5VYAC159G	Yellow	590	Water Clear	850	85			
L5N3SR	LTR5SRW075G	Hyper Red	638	White Diffused	25	140			
L5N3UB5	LOR5UB5C111G	Blue	465	Water Clear	4000	80			3.0
L5N3LPG6	LSR5LPG6D241G	Green	523	Green Diffused	900	140			3.1
L5N3UW5	LRR5UW5C193G	White	(0.28,0.27)	White Diffused	1000	100	3.0		

### L517 (Dual Color) Dimension 5 mm

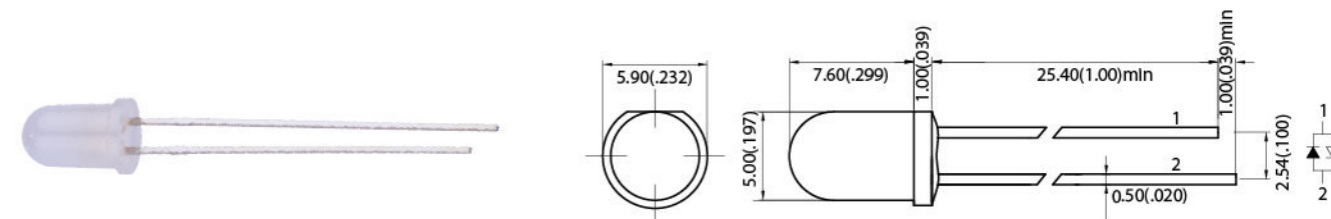

#### Specifications

Series	Ref. PN	Color	Wavelength $\lambda_d$ (nm)/ CIE (x,y)	Resin Type	Typ. Luminous Intensity $I_v$ (mcd)	Viewing Angle (deg.)	Typ. Forward Voltage $V_F$ (V)	Forward Current $I_F$ (mA)
L517GG	LTR5GGD142G	Yellow Green	570	Green Diffused	4	60	1.9	20
L517GY	LHR5GY063	Yellow Green Yellow	570 587	White Diffused	50 60			
L517EG	LJR5EGW025G	Super Red Yellow Green	628 570		10 12	100		
L517EY	LPR5EYW501G	Red Yellow	632 585		15 10	120		

L519 (Dual Color) Dimension 5 mm

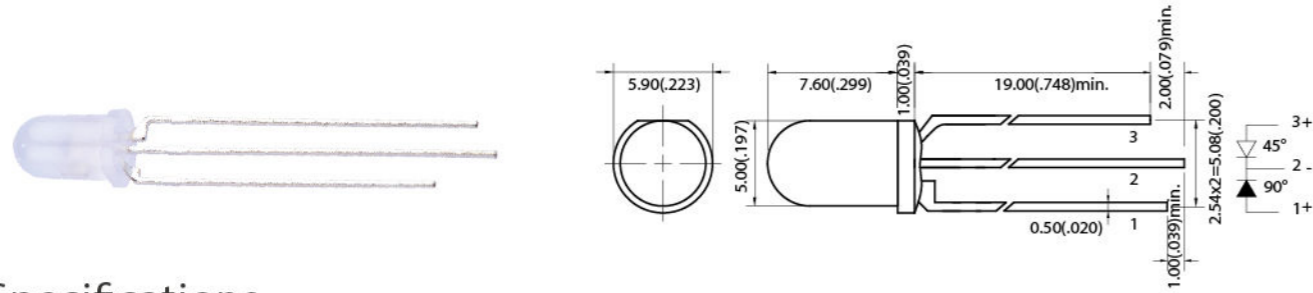

Specifications

Series	Ref. PN	Color	Wavelength $\lambda_d$ (nm)/ CIE (x,y)	Resin Type	Typ. Luminous Intensity $I_v$ (mcd)	Viewing Angle (deg.)	Typ. Forward Voltage $V_F$ (V)	Forward Current $I_F$ (mA)
L519EG	LQRSEGW293G	Super Red Yellow Green	630 571	White Diffused	40 12	120	2.1 2.2	20
L519RLPG6	LTR5VEALPG6W171G	Super Red Green	620 525		290 920	110	2.1 2.8	

L5T8 (RGB) Dimension 5 mm

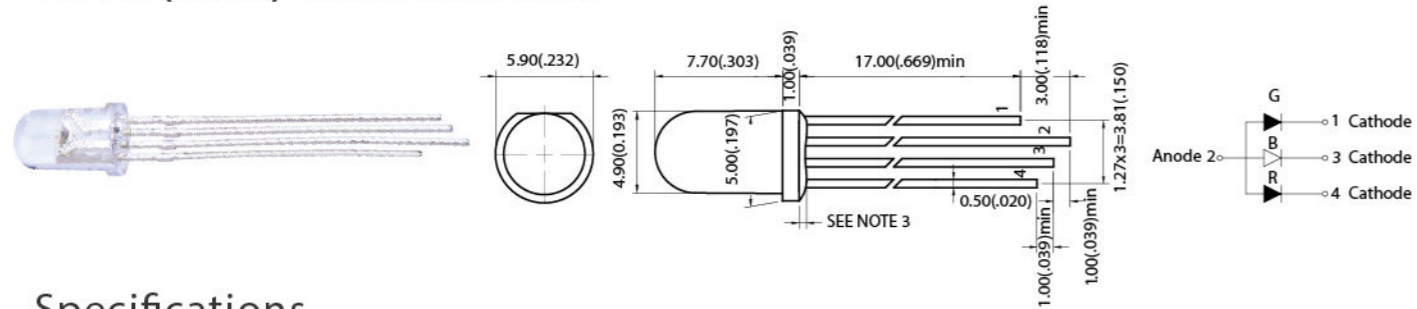

Specifications

Series	Ref. PN	Color	Wavelength $\lambda_d$ (nm)/ CIE (x,y)	Resin Type	Typ. Luminous Intensity $I_v$ (mcd)	Viewing Angle (deg.)	Typ. Forward Voltage $V_F$ (V)	Forward Current $I_F$ (mA)
L5T8RGB	LQR5RGBW418G	Red Green Blue	628 525 460	White Diffused	600 1500 300	70	2.0 2.8 2.9	20

L813 (Single Color) Dimension 8 mm

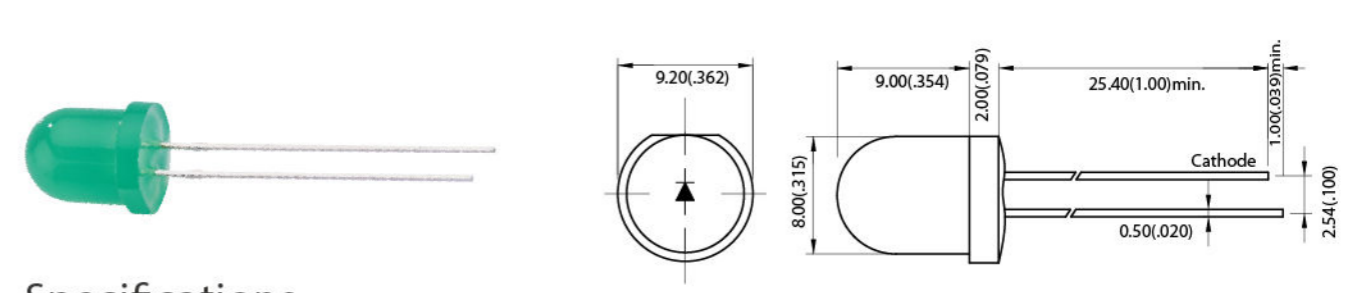

Specifications

Series	Ref. PN	Color	Wavelength $\lambda_d$ (nm)/ CIE (x,y)	Resin Type	Typ. Luminous Intensity $I_v$ (mcd)	Viewing Angle (deg.)	Typ. Forward Voltage $V_F$ (V)	Forward Current $I_F$ (mA)
L813G	LKR8VG3D551	Yellow Green	570	Green Diffused	30	150	2.0	20
L813Y	LZR8YD018G	Yellow	590	Yellow Diffused	20	170	1.9	
L813E	LRR8VED252G	Super Red	622	Red Diffused	700	40	1.9	
L813UB5	LVR8UB5D019G	Blue	458	Blue Diffused	1000	35	3.1	
L813LPG6	LRR8LPG6D251G	Green	522	Green Diffused	700	60	3.0	
L813UW5	LTR8UW5C097G	Green	(0.29, 0.30)	Water Clear	5000	25	3.1	

L833 (Single Color) Dimension 10 mm

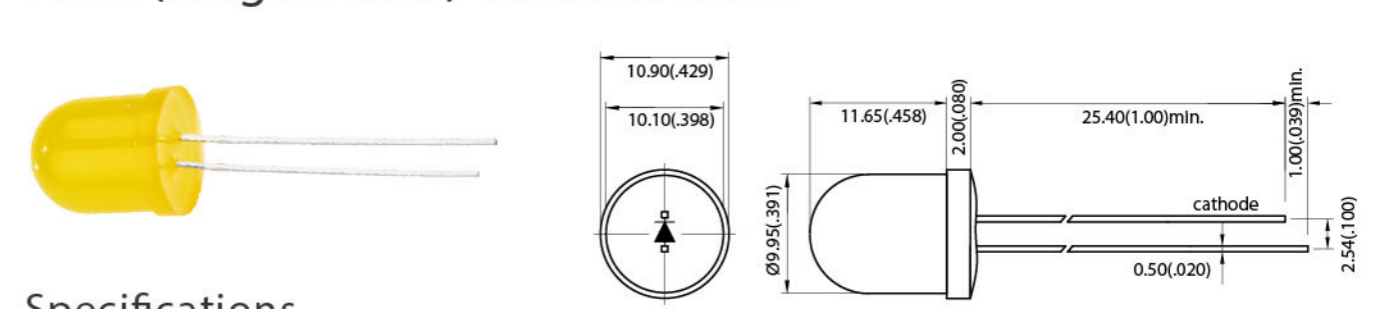

Specifications

Series	Ref. PN	Color	Wavelength $\lambda_d$ (nm)/ CIE (x,y)	Resin Type	Typ. Luminous Intensity $I_v$ (mcd)	Viewing Angle (deg.)	Typ. Forward Voltage $V_F$ (V)	Forward Current $I_F$ (mA)
L833G	LVR10GD022G	Yellow Green	570	Green Diffused	5	150	1.9	20
L833Y	LZR10YD019G	Yellow	590	Yellow Diffused	15	170	1.9	
L833E	LVR10ED023G	Super Red	622	Red Diffused	10	150	2.1	
L833SR	LVR10SRD024G	Hyper Red	645	Red Diffused	15	150	2.1	
L833UB5	LLR8UB5W059G	Blue	465	White Diffused	60	170	3.0	
L833UW5	LPR10UW5C081G	White	(0.41, 0.39)	Water Clear	2000	30	3.0	

L403 (Single Color) Dimension 2\*5\*7 mm

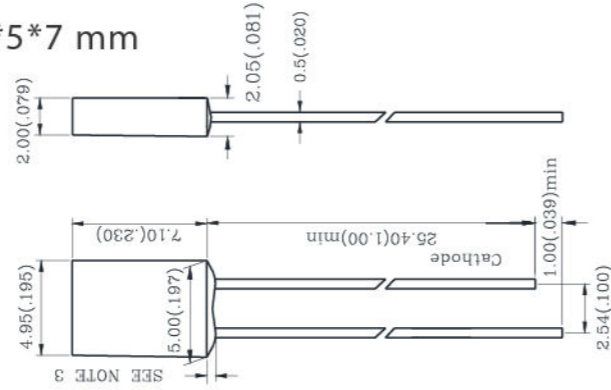

Specifications

Series	Ref. PN	Color	Wavelength $\lambda_d$ (nm)/ CIE (x,y)	Resin Type	Typ. Luminous Intensity $I_v$ (mcd)	Viewing Angle (deg.)	Typ. Forward Voltage $V_F$ (V)	Forward Current $I_F$ (mA)
L403G	LTS5GD005G	Yellow Green	570	Green Diffused	20	60	2.1	20
L403Y	LZS5LY5D042G	Yellow	590	Yellow Diffused	95	150		
L403E	LVS4ED034G	Super Red	635	Red Diffused	12	120	1.9	
L403SR	LVS4SRD035G	Hyper Red	645	Red Diffused	40	110	3.0	
L403UB5	LQS4UB5D491G	Blue	464	Blue Diffused	66			
L403LPG6	LQS4LPG6D402G	Green	528	Green Diffused	230			

L423 (Single Color) Dimension 2.5\*7.0\*7.5 mm

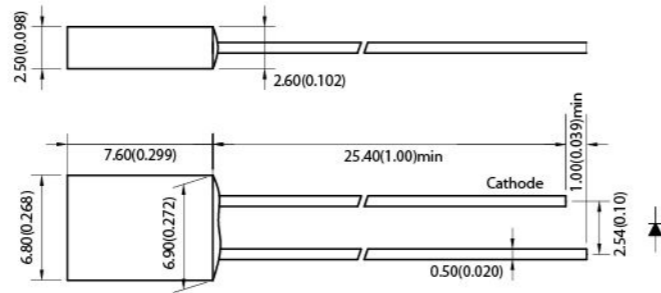

Specifications

Series	Ref. PN	Color	Wavelength $\lambda_d$ (nm)/ CIE (x,y)	Resin Type	Typ. Luminous Intensity $I_v$ (mcd)	Viewing Angle (deg.)	Typ. Forward Voltage $V_F$ (V)	Forward Current $I_F$ (mA)
L423G	LVS7GD038G	Yellow Green	570	Green Diffused	4	120	1.9	20
L423Y	LVS7VYD036G	Yellow	590	Yellow Diffused	50	80	2.0	
L423E	LVS7ED039G	Super Red	630	Red Diffused	120	120	1.9	
L423SR	LVS7SRD037G	Hyper Red	640	Red Diffused	11	80	1.9	
L423UB5	LTS7UB5C103G	Blue	465	Water Clear	400	80	3.0	
L423LPG6	LZS7LPG6D043G	Green	520	Green Diffused	650	150	3.0	

L604 (Single Color) Dimension 1.9\*3.1\*4.0 mm

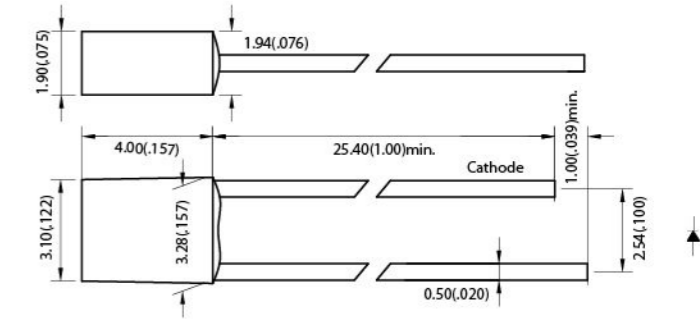

Specifications

Series	Ref. PN	Color	Wavelength $\lambda_d$ (nm)/ CIE (x,y)	Resin Type	Typ. Luminous Intensity $I_v$ (mcd)	Viewing Angle (deg.)	Typ. Forward Voltage $V_F$ (V)	Forward Current $I_F$ (mA)
L604G	LPS3GD127G	Yellow Green	569	Green Diffused	10	60	2.1	20
L604Y	LOS3LY3C188G	Yellow	589	Water Clear	70	60	2.1	
L604E	LSS3VEC090G	Super Red	623	Water Clear	460	120	2.0	
L604SR	LVS3SRD066G	Hyper Red	642	Red Diffused	25	120	1.9	
L604UB5	LVS3UB5C049G	Blue	470	Water Clear	300	120	3.0	
L604LPG6	LTS3LPG6T098G	Green	525	Green Transparent	300	120	3.0	

L419 (Dual Color) Dimension 2\*5\*7 mm

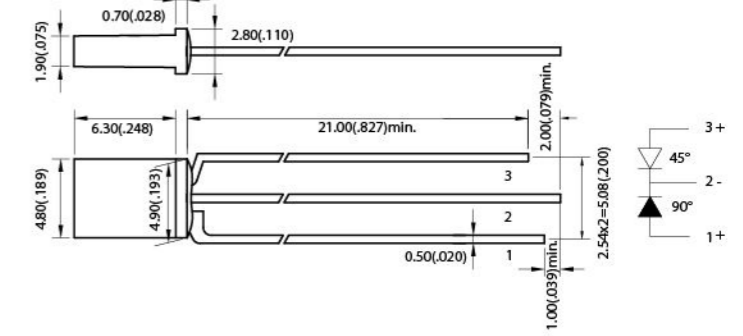

Specifications

Series	Ref. PN	Color	Wavelength $\lambda_d$ (nm)/ CIE (x,y)	Resin Type	Typ. Luminous Intensity $I_v$ (mcd)	Viewing Angle (deg.)	Typ. Forward Voltage $V_F$ (V)	Forward Current $I_F$ (mA)
L419YG	LWS5YGW149G	Yellow	590	White Diffused	20	130	1.9	20
		Yellow Green	574		10			
L419RUB5	LRS6VEUB5W277G	Super Red	620		70	95	1.9	
		Blue	461		54			
L419RLPG6	LLSSHURLPG6W304G	Super Red	627		50	120	1.9	
		Green	525		220			

### L409 (Single Color) Dimension 2\*5\*7 mm

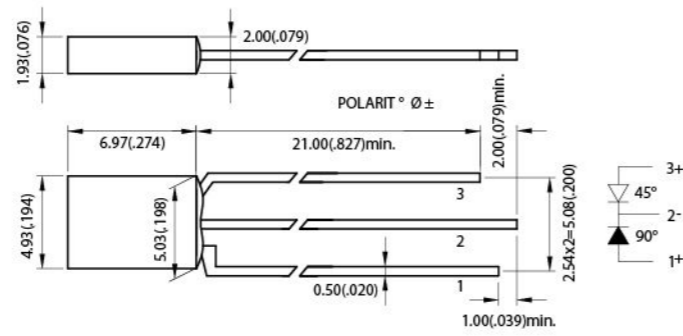

#### Specifications

Series	Ref. PN	Color	Wavelength $\lambda_d$ (nm)/ CIE (x,y)	Resin Type	Typ. Luminous Intensity $I_v$ (mcd)	Viewing Angle (deg.)	Typ. Forward Voltage $V_F$ (V)	Forward Current $I_F$ (mA)
L409EG	LUS4EGW066G	● Super Red ● Yellow Green	635 573	White Diffused	10 3	120	2.0 2.2	20
L409UB5VES	LQS4UB5VESW490G	● Blue ● Amber	464 603		76 66		3.0 2.0	
L409UB5HUR	LOS4UB5HURW297G	● Blue	465		50		3.0	
		● Super Red	623				1.9	

### L889 (RGB) Dimension 3.5\*4.8\*7.3 mm

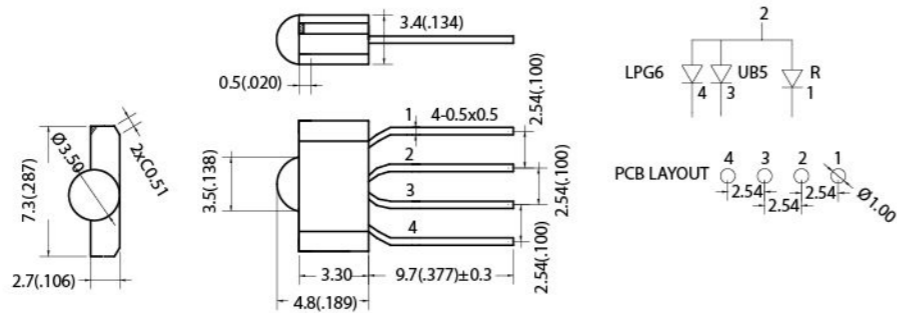
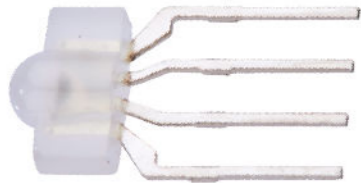

#### Specifications

Series	Ref. PN	Color	Wavelength $\lambda_d$ (nm)/ CIE (x,y)	Resin Type	Typ. Luminous Intensity $I_v$ (mcd)	Viewing Angle (deg.)	Typ. Forward Voltage $V_F$ (V)	Forward Current $I_F$ (mA)
L889RGB	LQS8RGBW538G	● Super Red	628	White Diffused	40	65	1.9	5
		● Green	530		250		2.9	
		● Blue	470		40		2.9	

### L314 (TBSH)

Part No.	H
L314XX-TBS 180	18.0mm
L314XX-TBS 190	19.0mm
L314XX-TBS 200	20.0mm
L314XX-TBS 220	22.0mm
L314XX-TBS 240	24.0mm

#### Specifications

Series	Ref. PN	Color	Wavelength $\lambda_d$ (nm)/ CIE (x,y)	Resin Type	Typ. Luminous Intensity $I_v$ (mcd)	Viewing Angle (deg.)	Typ. Forward Voltage $V_F$ (V)	Forward Current $I_F$ (mA)
L314LPG6C-TBSH	LVR3LPG6C028G	● Green	525	Water Clear	12000	30	3.0	20
L314GD-TBSH	LXR3VG3D036G	● Yellow Green	572	Green Diffused	90	40	1.9	
L314YT-TBSH	LXR3YT152G	● Yellow	589	Yellow Transparent	220	60	1.9	
L314VEXC-TBSH	LVR3VEXC134G	● Red	620	Water Clear	10000	12	2.0	

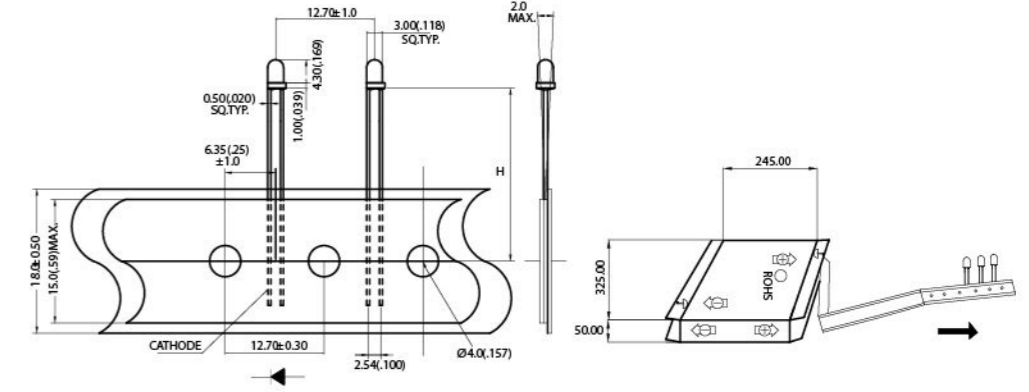

### L314 (TRSH)

Part No.	H
L314XX-TRS 180	18.0mm
L314XX-TRS 190	19.0mm
L314XX-TRS 200	20.0mm
L314XX-TRS 220	22.0mm
L314XX-TRS 240	24.0mm

#### Specifications

Series	Ref. PN	Color	Wavelength $\lambda_d$ (nm)/ CIE (x,y)	Resin Type	Typ. Luminous Intensity $I_v$ (mcd)	Viewing Angle (deg.)	Typ. Forward Voltage $V_F$ (V)	Forward Current $I_F$ (mA)
L314GD-TRSH	LTR3VG3D165G	● Yellow Green	570	Green Diffused	100	60	1.9	20
L314HURT-TRSH	LQR3HURT420G	● Red	622	Red Transparent	1500	20		
L314ET-TRSH	LZR3ET059G	● Red	635	Red Transparent	250	20		

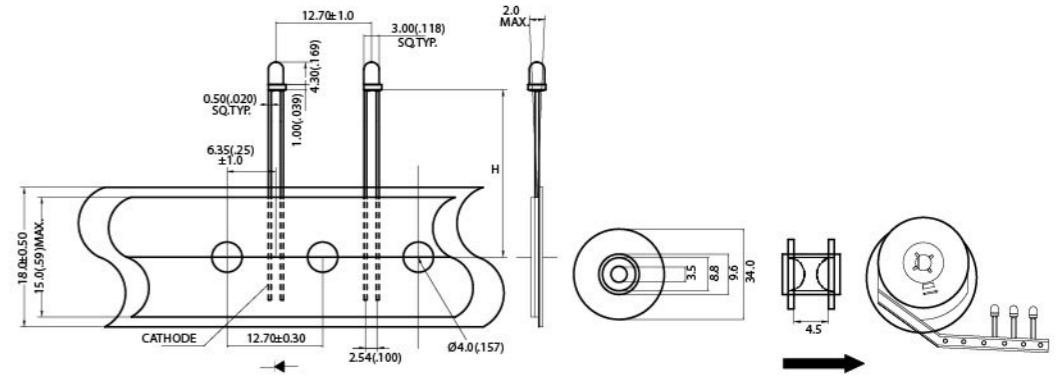

### L513 (TBSH)

Part No.	H
L-513XX-TBS 180	18.0mm
L-513XX-TBS 190	19.0mm
L-513XX-TBS 200	20.0mm
L-513XX-TBS 220	22.0mm
L-513XX-TBS 240	24.0mm

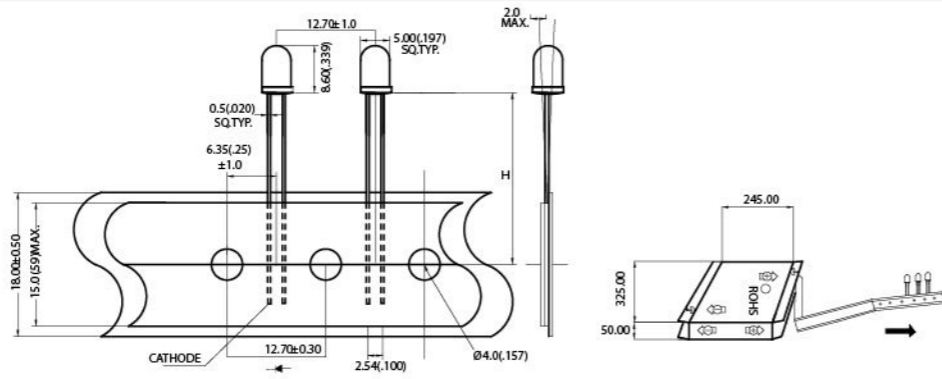

### Specifications

Series	Ref. PN	Color	Wavelength $\lambda_d$ (nm)/CIE (x,y)	Resin Type	Typ. Luminous Intensity $I_v$ (mcd)	Viewing Angle (deg.)	Typ. Forward Voltage $V_f$ (V)	Forward Current $I_f$ (mA)
L513LPG6C-TBSH	LZR5LPG6C017G	Green	520	Water Clear	13000	50	2.8	
L513GD-TBSH	LTR5GD020G	Yellow Green	569	Green Diffused	60	30	2.0	
L513VYXC-TBSH	LWR5VYXC168GA	Yellow	588	Water Clear	8000	10		20
L513LRC-TBSH	LVR5LRC108G	Red	630	Water Clear	1800	15	1.9	
L513SRD-TBSH	LXR5SRD089G	Red	640	Red Diffused	50	55		

### L513 (TRSH)

Part No.	H
L-513XX-TRS 180	18.0mm
L-513XX-TRS 190	19.0mm
L-513XX-TRS 200	20.0mm
L-513XX-TRS 220	22.0mm
L-513XX-TRS 240	24.0mm

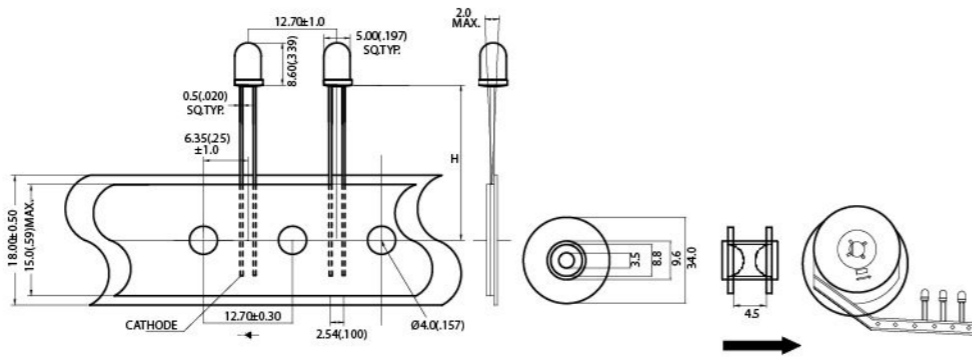

### Specifications

Series	Ref. PN	Color	Wavelength $\lambda_d$ (nm)/CIE (x,y)	Resin Type	Typ. Luminous Intensity $I_v$ (mcd)	Viewing Angle (deg.)	Typ. Forward Voltage $V_f$ (V)	Forward Current $I_f$ (mA)
L513GD-TRSH	LRR5GD326GA	Yellow Green	572	Green Diffused	10	40	2.0	
L513YD-TRSH	LVR5YD071G	Yellow	590	Yellow Diffused	120	50	1.9	
L513VEXC-TRSH	LSR5VEXC289GA	Red	620	Water Clear	6000	35	2.0	

### L513 (TBFHJ)

Part No.	J
L-513XX-TBF 180A	3.0mm
L-513XX-TBF 190B	4.0mm
L-513XX-TBF 200C	5.0mm
L-513XX-TBF 220D	6.0mm
L-513XX-TBF 240E	7.0mm

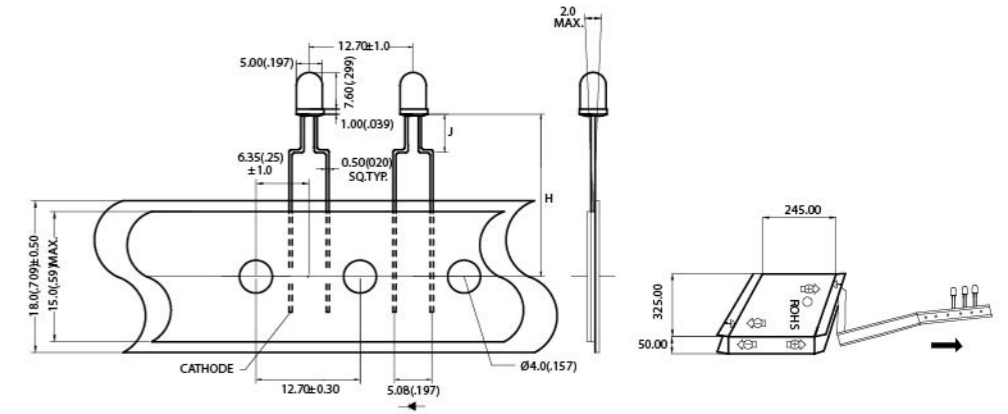

### Specifications

Series	Ref. PN	Color	Wavelength $\lambda_d$ (nm)/CIE (x,y)	Resin Type	Typ. Luminous Intensity $I_v$ (mcd)	Viewing Angle (deg.)	Typ. Forward Voltage $V_f$ (V)	Forward Current $I_f$ (mA)
L513LPG6C-TBFHJ	LSR5LPG6C134GA	Green	524	Water Clear	54000	15	3.0	
L513ED-TBFHJ	LZR5ED003G	Red	628	Red Diffused	320	40	1.9	
L513SRD-TBFHJ	LZR5SRD060G	Red	640	Red Diffused	150			20

# Holder Series Applications

- ◆ Computing server
- ◆ Signboard
- ◆ IoT indication
- ◆ Hi-Fi system
- ◆ Uninterruptible power system

## LHA143 (Single Color) Dimension 3 mm

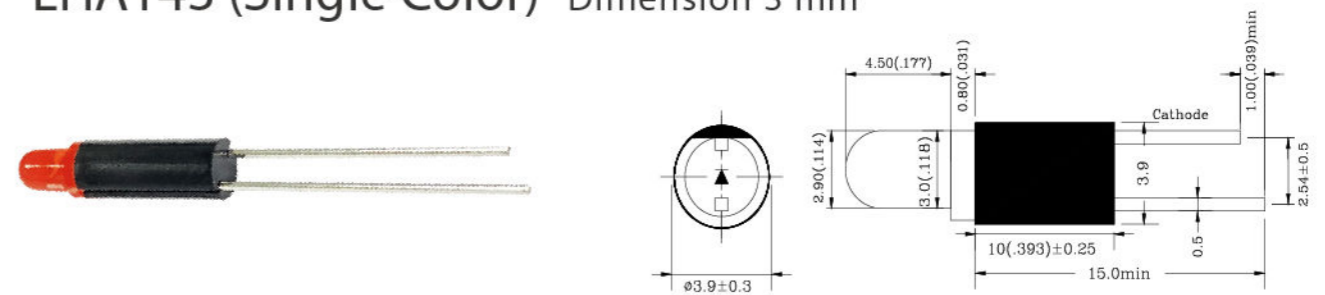

### Specifications

Ref. PN	LED Lamp	Color	Wavelength $\lambda_d$ (nm)/ CIE (x,y)	Resin Type	Typ. Luminous Intensity $I_v$ (mcd)	Viewing Angle (deg.)	Typ. Forward Voltage $V_f$ (V)	Forward Current $I_f$ (mA)
LHA14313	A=L3X4GD	Yellow Green	572	Green Diffused	20	60	2.2	20

## LH31C (Single Color) Dimension 3 mm

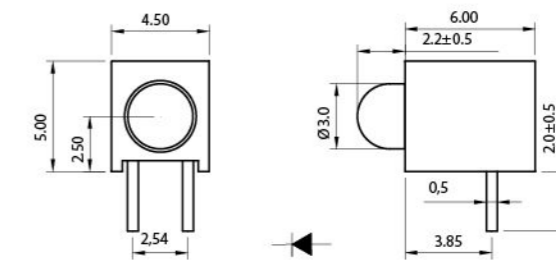

### Specifications

Ref. PN	LED Lamp	Color	Wavelength $\lambda_d$ (nm)/ CIE (x,y)	Resin Type	Typ. Luminous Intensity $I_v$ (mcd)	Viewing Angle (deg.)	Typ. Forward Voltage $V_f$ (V)	Forward Current $I_f$ (mA)
LH31C015P	A=L354UB5D	Blue	465	Blue Diffused	200	70	3	20
LH31C016P	A=L304UP5D	Purple	(0.19, 0.06)	Purple Diffused	450	40	2.9	
LH31C011C	A=L354GD	Yellow Green	570	Yellow Diffused	80	30	1.9	
LH31C022P	A=L354UW5W	White	(0.29, 0.29)	White Diffused	1200	60	3.0	



### LH512 (Single Color) Dimension 5 mm

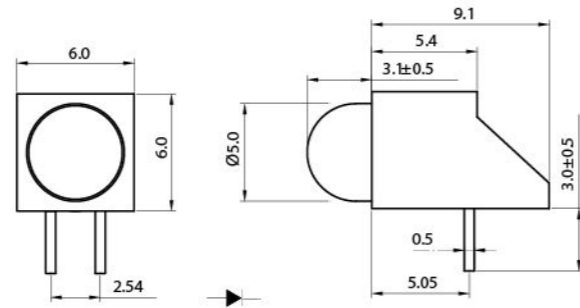

#### Specifications

Ref. PN	LED Lamp	Color	Wavelength $\lambda_d$ (nm)/ CIE (x,y)	Resin Type	Typ. Luminous Intensity $I_v$ (mcd)	Viewing Angle (deg.)	Typ. Forward Voltage $V_F$ (V)	Forward Current $I_F$ (mA)
LH512005B	A=L503GD	Yellow Green	572	Green Diffused	25	80	2.1	20
LH512008B	A=L503ED	Red	628	Red Diffused	25	2.0		
LH512007E	A=L503SRD	Red	640	Red Diffused	40	1.9		

### LH31C (Dual Color) Dimension 3 mm

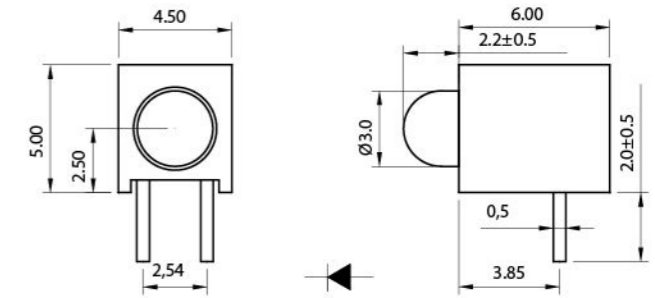

#### Specifications

Ref. PN	LED Lamp	Color	Wavelength $\lambda_d$ (nm)/ CIE (x,y)	Resin Type	Typ. Luminous Intensity $I_v$ (mcd)	Viewing Angle (deg.)	Typ. Forward Voltage $V_F$ (V)	Forward Current $I_F$ (mA)
LH31C017P	A=L357EGW	Red	628	White Diffused	12	120	2.1	20
		Yellow Green	568		15		2.0	

### LH513 (Single Color) Dimension 5 mm

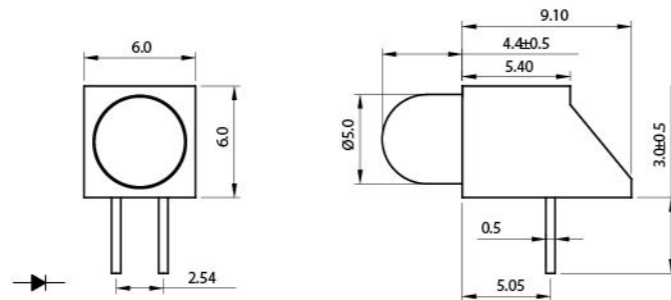

#### Specifications

Ref. PN	LED Lamp	Color	Wavelength $\lambda_d$ (nm)/ CIE (x,y)	Resin Type	Typ. Luminous Intensity $I_v$ (mcd)	Viewing Angle (deg.)	Typ. Forward Voltage $V_F$ (V)	Forward Current $I_F$ (mA)
LH513005B	A=L523GD	Yellow Green	568	Green Diffused	20	80	1.9	20
LH513008B	A=L523ED	Red	628	Red Diffused	10		2.1	
LH513009E	A=L523SRD	Red	640	Red Diffused	20		1.9	

### LH31F (Dual Color) Dimension 3 mm

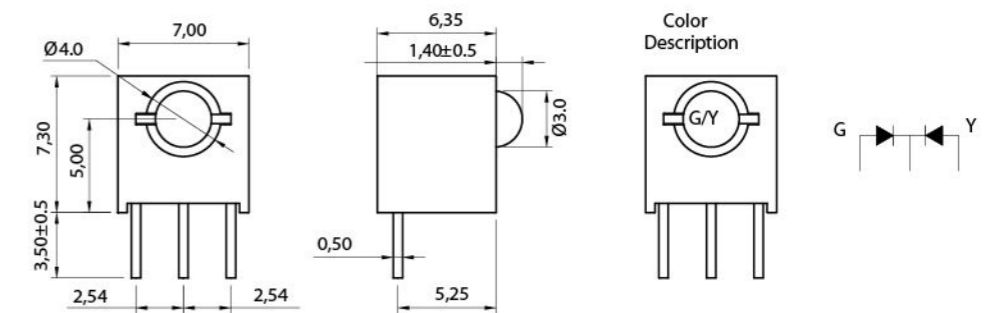

#### Specifications

Ref. PN	LED Lamp	Color	Wavelength $\lambda_d$ (nm)/ CIE (x,y)	Resin Type	Typ. Luminous Intensity $I_v$ (mcd)	Viewing Angle (deg.)	Typ. Forward Voltage $V_F$ (V)	Forward Current $I_F$ (mA)
LH31F818B	A=L359VEXLPG6W	Red	622	White Diffused	750	110	1.9	20
		Green	522		2100		3.0	
LH31F104A	A=L359EGW	Red	630		18	100	1.9	
		Green	570		14			

LH523 (Single Color) Dimension 5 mm

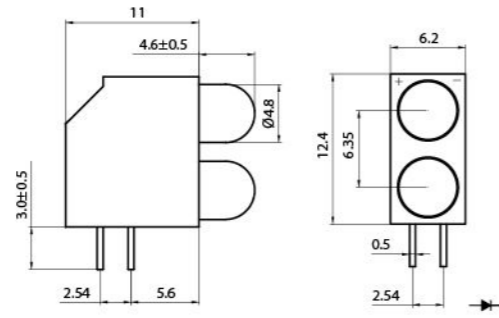

Specifications

Ref. PN	LED Lamp	Color	Wavelength $\lambda_d$ (nm)/ CIE (x,y)	Resin Type	Typ. Luminous Intensity $I_v$ (mcd)	Viewing Angle (deg.)	Typ. Forward Voltage $V_F$ (V)	Forward Current $I_F$ (mA)
LH523005B	A=B=L523GD	Yellow Green	568	Green Diffused	25	80	1.9	20
LH523008B	A=B=L523ED	Red	633	Red Diffused	20			

LH32K (Dual Color) Dimension 3 mm

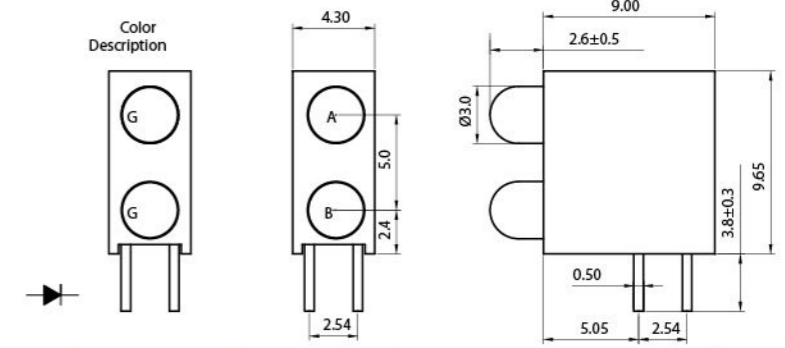

Specifications

Ref. PN	LED Lamp	Color	Wavelength $\lambda_d$ (nm)/ CIE (x,y)	Resin Type	Typ. Luminous Intensity $I_v$ (mcd)	Viewing Angle (deg.)	Typ. Forward Voltage $V_F$ (V)	Forward Current $I_F$ (mA)
LH32K048F	A=3524ED	Red	628	Red Diffused	30	50	1.9	20
	B=3524GD	Yellow Green	570	Green Diffused	15			
LH32K514C	A=3524GD	Yellow Green	570	Green Diffused	35	80	3.0	20
	B=354UB5D	Blue	463	Blue Diffused	100			
LH32K525E	A=354YD	Yellow	588	Yellow Diffused	30	55	1.9	20
	B=354SRD	Red	640	Red Diffused	75			

LH32K (Single Color) Dimension 3 mm

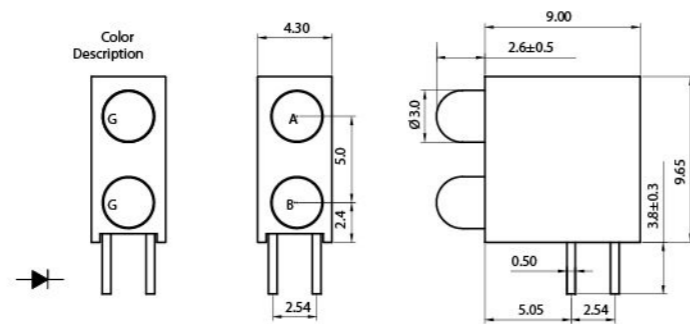

Specifications

Ref. PN	LED Lamp	Color	Wavelength $\lambda_d$ (nm)/ CIE (x,y)	Resin Type	Typ. Luminous Intensity $I_v$ (mcd)	Viewing Angle (deg.)	Typ. Forward Voltage $V_F$ (V)	Forward Current $I_F$ (mA)
LH32K036F	A=B=L3524GD	Yellow Green	570	Green Diffused	10	60	1.9	20
LH32K046F	A=B=L354ED	Red	628	Red Diffused	30	50		
LH32K066E	A=B=L354UB5D	Blue	465	Blue Diffused	150	120	3.0	20

LH33C (Dual Color) Dimension 3 mm

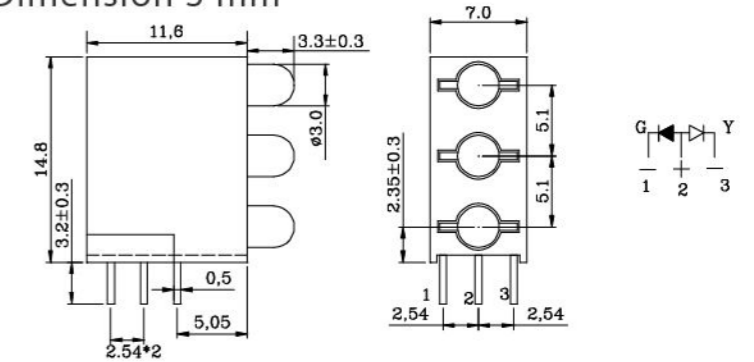

Specifications

Ref. PN	LED Lamp	Color	Wavelength $\lambda_d$ (nm)/ CIE (x,y)	Resin Type	Typ. Luminous Intensity $I_v$ (mcd)	Viewing Angle (deg.)	Typ. Forward Voltage $V_F$ (V)	Forward Current $I_F$ (mA)
LH33C219D-HTS	A=B=C=L329GYW	Yellow Green	570	White Diffused	12	90	1.9	20
		Yellow	589		8			
LH33C203D-HTS	A=B=C=L329EGW	Red	624	White Diffused	12	80	2.0	20
		Yellow Green	570		8			

LH34A Dimension 3 mm

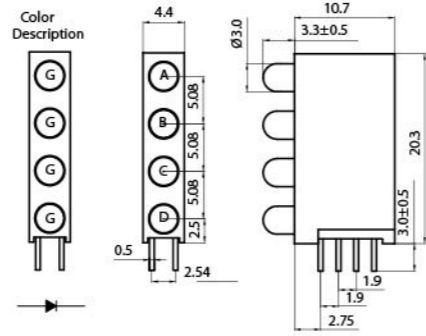

Specifications

Ref. PN	LED Lamp	Color	Wavelength $\lambda_d$ (nm)/ CIE (x,y)	Resin Type	Typ. Luminous Intensity $I_v$ (mcd)	Viewing Angle (deg.)	Typ. Forward Voltage $V_F$ (V)	Forward Current $I_F$ (mA)
LH34A006E	A=B=C=D=L3541GD	Yellow Green	568	Green Diffused	30	80	1.9	20
LH34A032E	A=B=C=D=LGR3E018	Red	633	Red Diffused	30	60	2.1	
LH34A036E	A=C=L3541GD B=D=L3541YD	Yellow Green Yellow	570 589	Green Diffused Yellow Diffused	25	60 80	1.9	

LH34D Dimension 3 mm

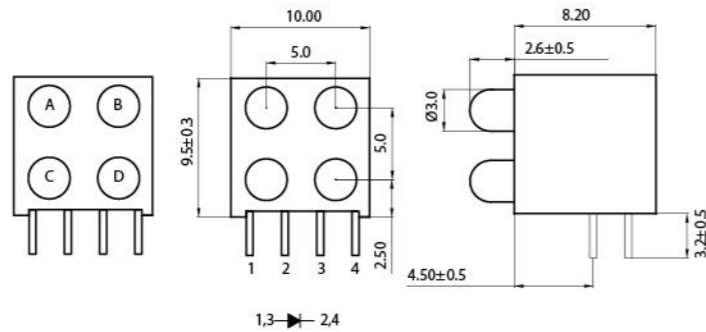

Specifications

Ref. PN	LED Lamp	Color	Wavelength $\lambda_d$ (nm)/ CIE (x,y)	Resin Type	Typ. Luminous Intensity $I_v$ (mcd)	Viewing Angle (deg.)	Typ. Forward Voltage $V_F$ (V)	Forward Current $I_F$ (mA)
LH34D201C	A=B=C=L324GD	Yellow Green	570	Green Diffused	20	60	2	20
	D=L324YD	Yellow	589	Yellow Diffused			2.1	
LH34D202C	A=L324YD	Yellow	589	Yellow Diffused	20	60	2	20
	B=D=L324GD	Yellow Green	570	Green Diffused			2	
	C=L324SRD	Red	640	Red Diffused			2.1	

LH35A Dimension 3 mm



Specifications

Ref. PN	LED Lamp	Color	Wavelength $\lambda_d$ (nm)/ CIE (x,y)	Resin Type	Typ. Luminous Intensity $I_v$ (mcd)	Viewing Angle (deg.)	Typ. Forward Voltage $V_F$ (V)	Forward Current $I_F$ (mA)
LH35A005E	A=L327LESLPG6W	Super Amber Green	605 525	White Diffused	200	70	2.0 3.1	20
	B=L3243UB5C C=L324LPG6D	Blue Green	465 525	Water Clear Green Diffused	1500 600	30 150	3.0 3.0	
	D=E=L324LESLPG6W	Orange Green	605 525	White Diffused	80 150	150	2.0 3.1	

LH36A Dimension 3 mm

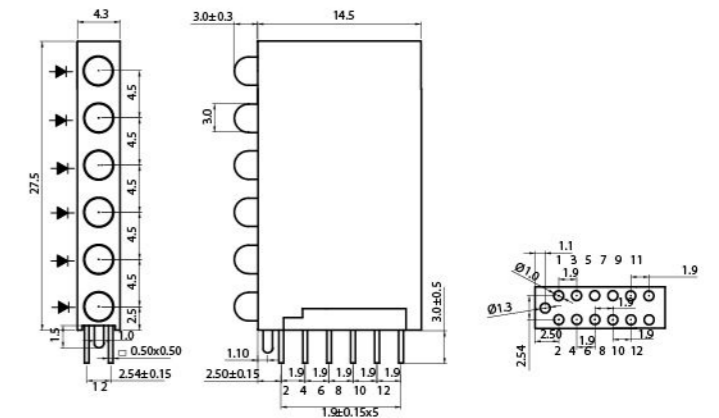

Specifications

Ref. PN	LED Lamp	Color	Wavelength $\lambda_d$ (nm)/ CIE (x,y)	Resin Type	Typ. Luminous Intensity $I_v$ (mcd)	Viewing Angle (deg.)	Typ. Forward Voltage $V_F$ (V)	Forward Current $I_F$ (mA)
LH36A100B-HTS	A=B=C=D=E=F=L354GD	Yellow Green	570	Green Diffused	10	80	1.9	20
LH36A101B-HTS	A=B=C=E=F=L354GD	Yellow Green	570	Green Diffused	10	80	1.9	20
	D=L354ED	Red	634	Red Diffused			1.8	

### LH385 Dimension 3 mm

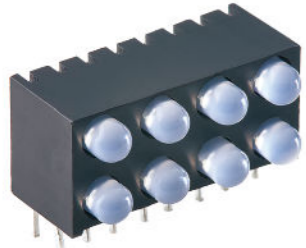

#### Specifications

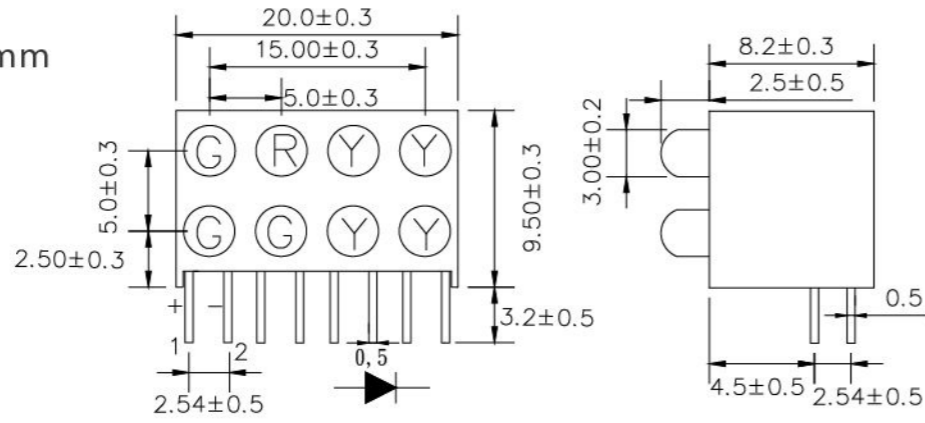

Ref. PN	LED Lamp	Color	Wavelength $\lambda_d$ (nm)/ CIE (x,y)	Resin Type	Typ. Luminous Intensity $I_v$ (mcd)	Viewing Angle (deg.)	Typ. Forward Voltage $V_F$ (V)	Forward Current $I_F$ (mA)
LH385012C-HTS	A=E=F=L324GD	Yellow Green	569	Green Diffused	40		2.0	
	B=L324SRD	Red	640	Red Diffused	20	60	2.0	20
	C=D=G=H=L324YD	Yellow	589	Yellow Diffused	25		2.1	

### LH3G1 Dimension 3 mm



#### Specifications

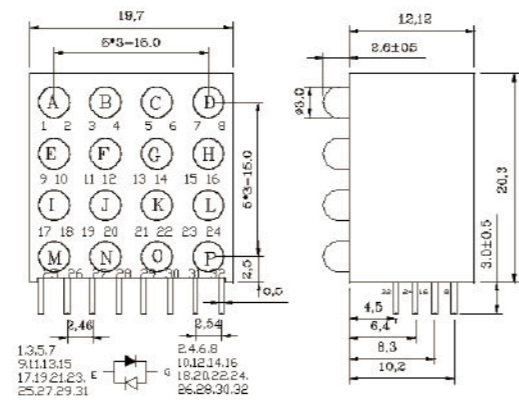

Ref. PN	LED Lamp	Color	Wavelength $\lambda_d$ (nm)/ CIE (x,y)	Resin Type	Typ. Luminous Intensity $I_v$ (mcd)	Viewing Angle (deg.)	Typ. Forward Voltage $V_F$ (V)	Forward Current $I_F$ (mA)
LH3G1016C	A~P=L324GD	Yellow Green	571	Green Diffused	50	60	1.9	20
LH3G1017C	A=B=C=D=E=F=G=I=J=K=L=M=N=O=L324GD	Yellow Green	571	Green Diffused	50	60	1.9	20
	H=L324YD	Yellow	589	Yellow Diffused	350	45		
	L=P=L324ED	Red	622	Red Diffused		40		