



# Component LED



## SMD & PLCC SURFACE MOUNT DEVICE

- IoT equipment
- Home appliances
- LED Lighting
- Gaming PC case or chassis
- Computer keyboard



光鼎電子股份有限公司

PARA LIGHT ELECTRONICS CO., LTD

11F, No. 8, Jiankang Rd., Zhonghe Dist., New Taipei City 23586, Taiwan

+886-2-2225-3733

para@para.com.tw

www.para.com.tw



INNOVATE  
COOPERATION  
INTEGRITY  
EVELOPMENT

Chairman Mr. David Ma  
Capital USD 37 million  
No. of Employee 676

## OUR HISTORY

PARA LIGHT was founded in 1987, and listed on Taiwan Stock Exchange (TWSE) in 2008 (ticker number 6226).

PARA LIGHT is now one of the global leaders in LED Design and Manufacturing. 9 years ago, PARA LIGHT established the first OPTICAL LAB, by which PARA LIGHT is able to provide Optical Solutions, and also expands our services to LED MODULE Design and Manufacturing.

PARA LIGHT's manufacturing facilities are located in China (Nanjing and Lianyungan), and Myanmar (Yangon), certified with ISO 14001, ISO 9001, and IATF 16949. PARA LIGHT produces high quality products complied to REACH and RoHS standard.

Sales offices are based in Taiwan, China, USA and India. Our sales team and certified distributors are located around the world to provide immediate services and prompt delivery to the customers.

Adhering to the enterprise philosophy of "customer first, service quality, creativity reality, skillfulness technique has always been the mission statement at the Para Light Electronics.

## CATALOG

**SMD Series Top View**

Single Color	07
Dual Color	12
RGB	14

**SMD Series Side View**

Single Color	16
Dual Color	18
RGB	19

**SMD Series Dome Lens**

Single Color	20
Invisible LED	21

## CATALOG

**PLCC Series Top View**

Single Color	23
RGB	28
IR	30

**PLCC Series Side View**

Single Color	31
--------------	----

**PLCC Series Dome Lens**

IR	32
----	----



# SMD Series Applications

- ◆ Wearable device
- ◆ Mobile device
- ◆ Medical device
- ◆ Control panel
- ◆ IoT equipment
- ◆ TV backlight
- ◆ LED lighting



0402 (LC292) Dimension 1.0\*0.5\*0.4 mm

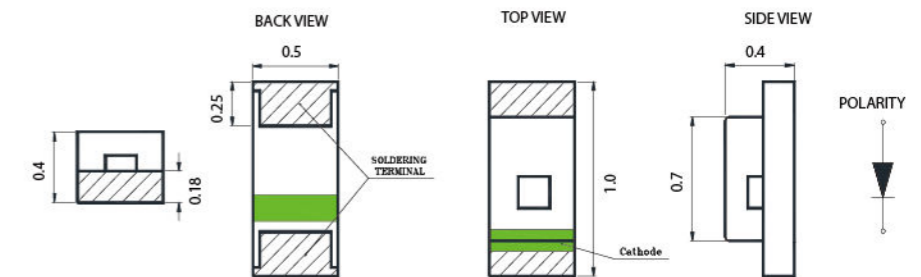
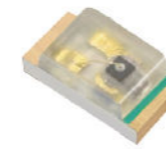

## Specifications

Ref. PN	Color	Wavelength $\lambda$ (nm)/ CIE (x,y)	Lens Type	Typ. Luminous Intensity $I_v$ (mcd)	Viewing Angle (deg.)	Typ. Forward Voltage $V_f$ (V)	Forward Current $I_f$ (mA)
LC292LBCT-5A	Blue	470	Water Clear	45	120	2.8	5
LC292LGCT-5A	Green	525		280		2.9	
LC292JGCT-5A	Green	571		25		2.0	
LC292JYCT-5A	Yellow	590		45		2.0	
LC292JRCT-5A	Red	630		28		2.0	
LC292JFCT-5A	Amber	604		45		2.0	
LC292JECT-5A	Orange	620		45		1.8	
LC292WDT-5A	White	(0.30, 0.30)		Yellow Diffused		210	



Ref. PN	Color	Wavelength $\lambda$ (nm)/ CIE (x,y)	Lens Type	Typ. Luminous Intensity $I_v$ (mcd)	Viewing Angle (deg.)	Typ. Forward Voltage $V_f$ (V)	Forward Current $I_f$ (mA)
LC292PJGCT-5A	Yellow Green	570	Water Clear	11.2	120	2.0	5
LC292PJYCT-5A	Yellow	590		45			
LC292PJRCT-5A	Super Red	623		45			



Ref. PN	Color	Wavelength $\lambda$ (nm)/ CIE (x,y)	Lens Type	Typ. Luminous Intensity $I_v$ (mcd)	Viewing Angle (deg.)	Typ. Forward Voltage $V_f$ (V)	Forward Current $I_f$ (mA)
LC292WDT-5A-D	White	(0.26, 0.26)	Yellow Diffused	250	130	2.8	20
LC292WDT-NW-YY		(0.315, 0.310)		210	120		

## 0603 (LC191) Dimension 1.6\*0.8\*0.6 mm

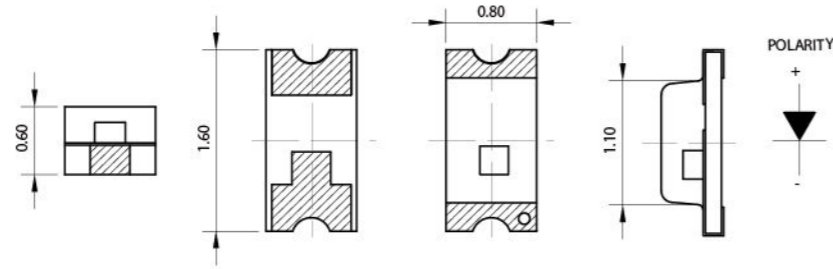
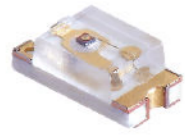

## Specifications

Ref. PN	Color	Wavelength $\lambda$ (nm)/ CIE (x,y)	Lens Type	Typ. Luminous Intensity $I_v$ (mcd)	Viewing Angle (deg.)	Typ. Forward Voltage $V_F$ (V)	Forward Current $I_F$ (mA)
LC191LBCT	Blue	470	Water Clear	100	130	3.0	20
LC191LGCT	Green	525		700		3.1	
LC191JGCT	Yellow Green	570		30		2.1	
LC191JYCT	Yellow	590		100		2.1	
LC191KYCT	Super Yellow	590		100			
LC191JFCT	Super Amber	605		80		2.0	
LC191JRCT	Super Red	631		50			
LC191WDT-5mA	White	(0.28, 0.28)		Yellow Diffused		280	

## 0603 (LC192) Dimension 1.6\*0.8\*0.4 mm

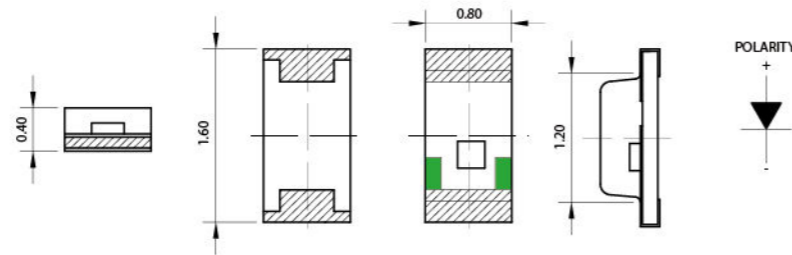

## Specifications

Ref. PN	Color	Wavelength $\lambda$ (nm)/ CIE (x,y)	Lens Type	Typ. Luminous Intensity $I_v$ (mcd)	Viewing Angle (deg.)	Typ. Forward Voltage $V_F$ (V)	Forward Current $I_F$ (mA)		
LC192LBCT	Blue	470	Water Clear	100	130	3.2	20		
LC192LGCT	Green	525		300		3.0	20		
LC192JGCT-5A	Yellow Green	569		10		2.0	5		
LC192JYCT	Yellow	590		80		2.05	20		
LC192KFCT	Super Amber	605		100		2.0	20		
LC192JRCT-5AK1	Super Red	631		28		1.9	5		
LC192WDT	White	(0.30, 0.30)		Yellow Diffused		150	130	2.8	5

## 0603 (LC192C) Dimension 1.6\*0.8\*0.4 mm

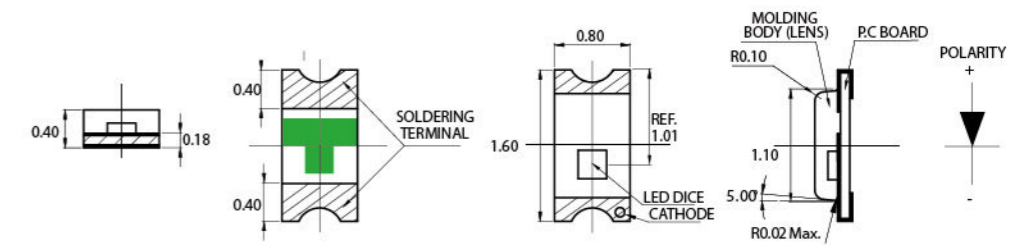

## Specifications

Ref. PN	Color	Wavelength $\lambda$ (nm)/ CIE (x,y)	Lens Type	Typ. Luminous Intensity $I_v$ (mcd)	Viewing Angle (deg.)	Typ. Forward Voltage $V_F$ (V)	Forward Current $I_F$ (mA)			
LC192CBCT-5A	Blue	470	Water Clear	30	130	2.8	5			
LC192CGCT-5A	Yellow Green	571		10		2.0				
LC192CYCT-5A	Yellow	590		38		1.8				
LC192CFCT-5A	Super Amber	605		38		1.9				
LC192CRCT-5A	Super Red	631		12						
LC192CWDT-HM	White	(0.30, 0.27)		Yellow Diffused		130		130	2.9	5

## 0201 (LC393) Dimension 0.65\*0.35\*0.45 mm

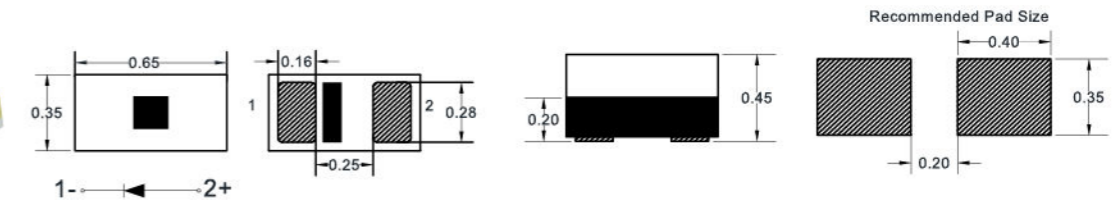
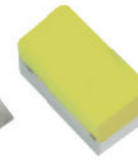
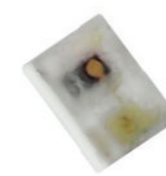

## Specifications

Ref. PN	Color	Wavelength $\lambda$ (nm)/ CIE (x,y)	Lens Type	Typ. Luminous Intensity $I_v$ (mcd)	Viewing Angle (deg.)	Typ. Forward Voltage $V_F$ (V)	Forward Current $I_F$ (mA)		
LC393KBCT-10A	Blue	522	Water Clear	468	120	3.0	30		
LC393LGCT-10A	Green	522		440		3.0			
LC393KYCT-10A	Yellow	595		75		2.2			
LC393KRCT-10A	Yellow	626		75		2.2			
LC393KFCT-10A	Orange	607		75		2.2			
LC393WDT-10A	White	(0.3237, 0.3369)		Yellow Planar Colloid		550		120	3.0

0805 (LC170) Dimension 2.0\*1.25\*0.8 mm

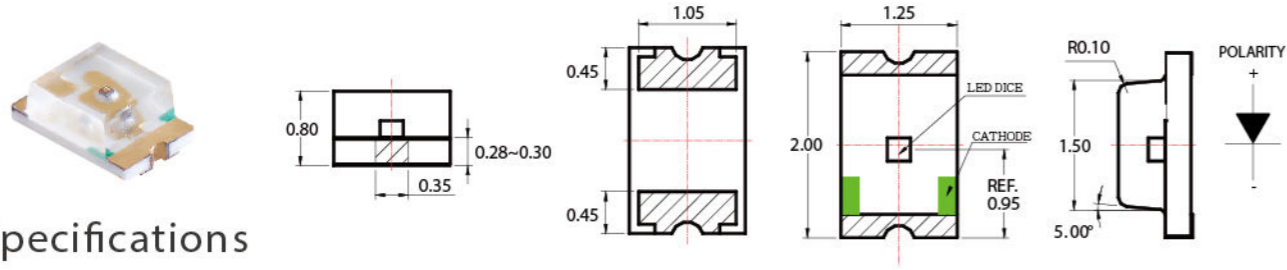

Specifications

Ref. PN	Color	Wavelength $\lambda$ (nm)/ CIE (x,y)	Lens Type	Typ. Luminous Intensity $I_v$ (mcd)	Viewing Angle (deg.)	Typ. Forward Voltage $V_F$ (V)	Forward Current $I_F$ (mA)
LC170LBCT	Blue	470	Water Clear	110	130	2.9	20
LC170LGCT	Green	525		300		3.1	
LC170JGCT	Yellow Green	570		40		2.1	
LC170JYCT	Yellow	590		70		2.1	
LC170JFCT	Super Amber	605		120		2.0	
LC170JRCT	Super Red	630		60		1.9	
LC170KRCT	Super Red	631		70		2.0	
LC170WDT	White	(0.30, 0.30)	Yellow Diffused	720	130	3.1	

1206 (LC150) Dimension 3.2\*1.6\*1.1 mm

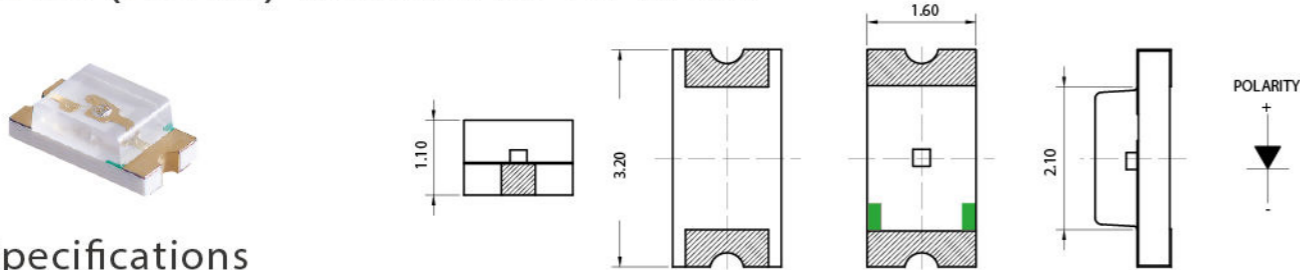

Specifications

Ref. PN	Color	Wavelength $\lambda$ (nm)/ CIE (x,y)	Lens Type	Typ. Luminous Intensity $I_v$ (mcd)	Viewing Angle (deg.)	Typ. Forward Voltage $V_F$ (V)	Forward Current $I_F$ (mA)
LC150LBCT	Blue	470	Water Clear	120	130	3.2	20
LC150LGCT	Green	525		300		3.1	
LC150KGCT	Super Green	570		30		2.05	
LC150JGCT	Yellow Green	570		40		2.1	
LC150JYCT	Yellow	590		80		2.1	
LC150KYCT	Super Yellow	590		100		2.0	
LC150JFCT	Super Amber	605		71		2.0	
LC150JRCT	Super Red	631	71	1.9			
LC150WDT	White	(0.3, 0.3)	Yellow Diffused	450	130	3.2	

0603 (LC196) Dimension 1.6\*0.8\*0.4 mm

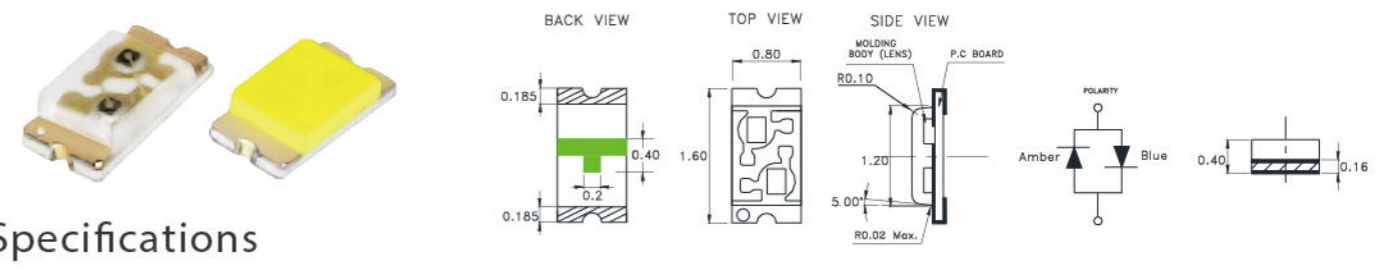

Specifications

Ref. PN	Color	Wavelength $\lambda$ (nm)/ CIE (x,y)	Lens Type	Typ. Luminous Intensity $I_v$ (mcd)	Viewing Angle (deg.)	Typ. Forward Voltage $V_F$ (V)	Forward Current $I_F$ (mA)	
LC196KGKYCT	Yellow Green	570	Water Clear	45	130	2.0	20	
	Super Yellow	590		112		2.0		
LC196KFLBCT	Super Amber	605		120		2.0		
	Super Blue	470		140		3.0		
LC196LGWDT	Super Green	525		Light Yellow Diffused		650		3.0
	White	(0.305, 0.300)				620		3.1

0603 (LC295) Dimension 1.6\*0.8\*0.6 mm

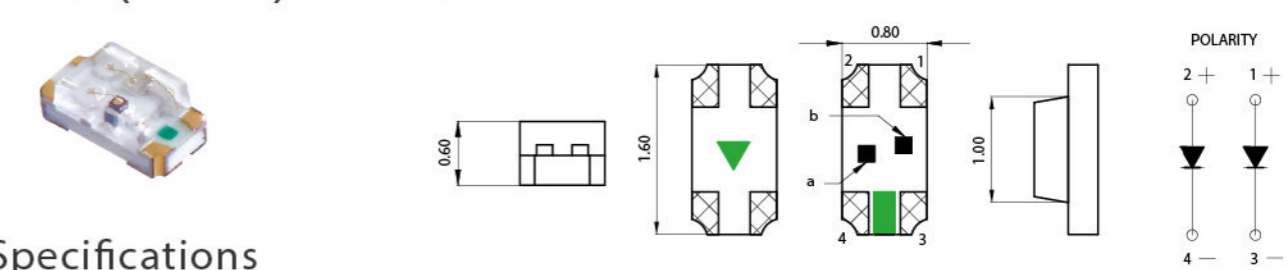

Specifications

Ref. PN	Color	Wavelength $\lambda$ (nm)/ CIE (x,y)	Lens Type	Typ. Luminous Intensity $I_v$ (mcd)	Viewing Angle (deg.)	Typ. Forward Voltage $V_F$ (V)	Forward Current $I_F$ (mA)
LC295JRJGCT	Super Red	630	Water Clear	47.5	130	1.9	20
	Yellow Green	570		20.5		2.0	
LC295JYJGCT	Yellow	590		72		1.9	
	Yellow Green	570		45		2.0	
LC295KYLGC-BIC-5A	Yellow	590		30		1.9	
	Green	525		250		2.6	
LC295JRLBCT	Super Red	631		60		2.0	
	Blue	470	160	3.1			
LC295JRWDT-5A	Super Red	630	Yellow Diffused	14	130	1.8	5
	White	(0.325, 0.300)		72		2.9	

0605 (LC195) Dimension 1.6\*1.5\*0.55 mm

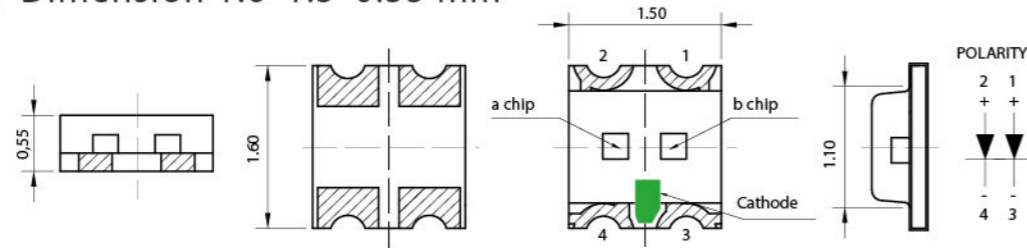

Specifications

Ref. PN	Color	Wavelength $\lambda$ (nm)/ CIE (x,y)	Lens Type	Typ. Luminous Intensity $I_v$ (mcd)	Viewing Angle (deg.)	Typ. Forward Voltage $V_F$ (V)	Forward Current $I_F$ (mA)
LC195JRJGCT	● Super Red	631	Water Clear	85	130	1.9	20
	● Yellow Green	570		30		2.0	
LC195JGJYCT	● Yellow	590		90		2.0	
	● Yellow Green	572		27		2.0	
LC195JYJGCT	● Yellow	590		35		2.0	
	● Yellow Green	570		18		2.0	
LC195JRLBCT	● Super Red	631		40		2.0	
	● Blue	470		150		3.0	
LC195JRLGCT-5A-FMT	● Super Red	631		17		1.85	
	● Green	525		280		2.7	
LC195JRWD-5A	● Super Red	630	18	2.0			
	○ White (0.29, 0.28)	(0.29, 0.28)	112	2.9			

0606 (LC19F) Dimension 1.6\*1.6\*0.6 mm

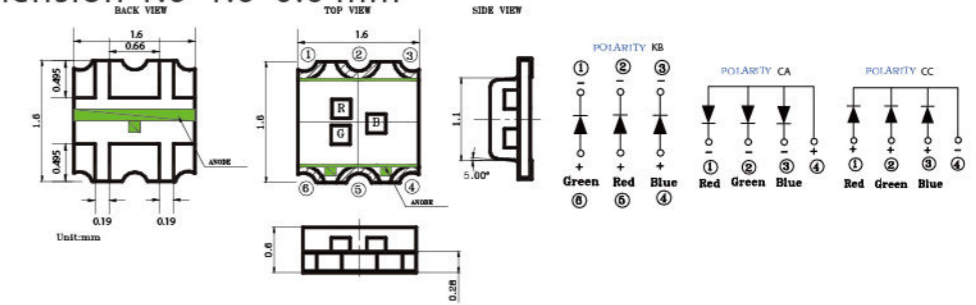

Specifications

Ref. PN	Color	Wavelength $\lambda$ (nm)/ CIE (x,y)	Lens Type	Typ. Luminous Intensity $I_v$ (mcd)	Viewing Angle (deg.)	Typ. Forward Voltage $V_F$ (V)	Forward Current $I_F$ (mA)
LC19F1RGBCT-KB	● Super Red	621	Water Clear	36	130	1.9	2
	● Green	528		120		2.3	
	● Blue	467		15		2.6	
LC19F1RGBCT-CA	● Super Red	623		112		1.9	
	● Green	525		450		3.1	
	● Blue	470		112		3.0	
LC19F1RGBCT-CC	● Super Red	623		320		2.0	
	● Green	525		450		3.1	
	● Blue	470		112		3.1	

0606 (LC19F1RBCT) Dimension 1.6\*1.6\*0.6 mm

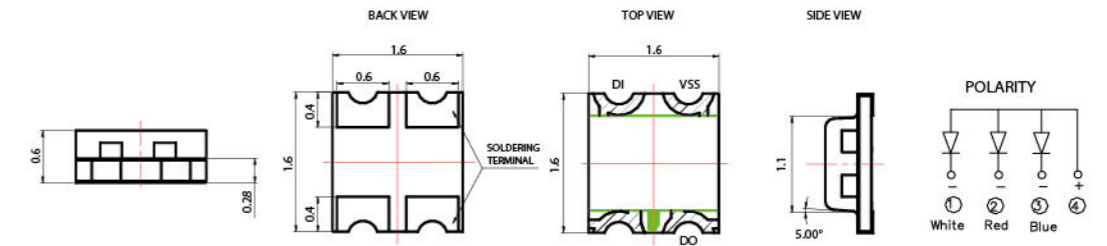

Specifications

Ref. PN	Color	Wavelength $\lambda$ (nm)/ CIE (x,y)	Lens Type	Typ. Luminous Intensity $I_v$ (mcd)	Viewing Angle (deg.)	Typ. Forward Voltage $V_F$ (V)	Forward Current $I_F$ (mA)
LC19F1RBWCT-CA-2.3A	● Super Red	620	Water Clear	28	130	1.8	2.3
	● Blue	470		71		2.7	
	○ White (0.29, 0.30)	(0.29, 0.30)		180		2.7	

0603 (LC29F1) Dimension 1.6\*0.8\*0.6 mm



Specifications

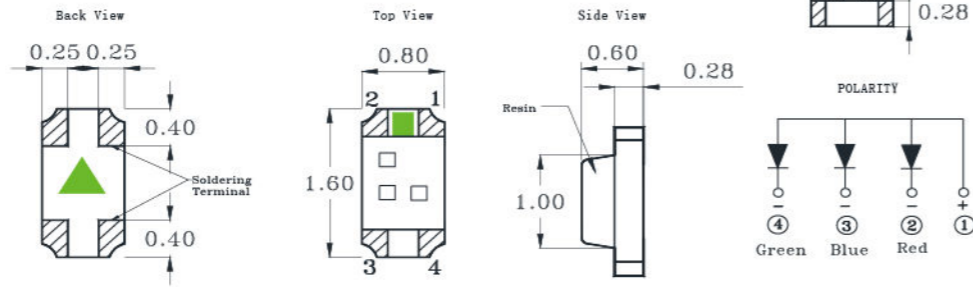

Ref. PN	Color	Wavelength $\lambda$ (nm)/ CIE (x,y)	Lens Type	Typ. Luminous Intensity $I_v$ (mcd)	Viewing Angle (deg.)	Typ. Forward Voltage $V_F$ (V)	Forward Current $I_F$ (mA)
LC29F1RBGCT-CA-2A	● Super Red	619	Water Clear	15	130	1.8	2
	● Super Blue	466		2.6			
	● Super Green	530		2.4			

0603 (LS193) Dimension 1.6\*0.60\*1.0 mm

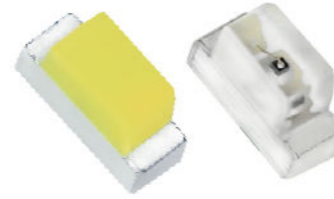

Specifications

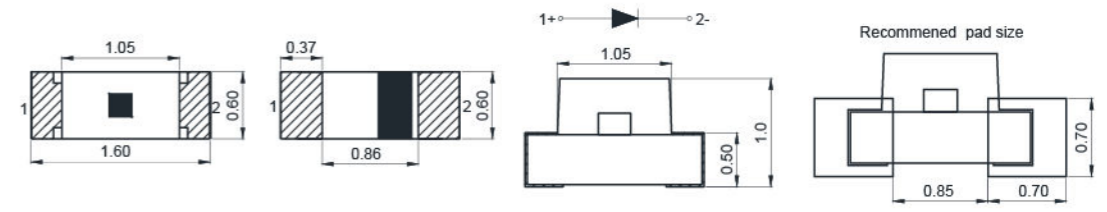

Ref. PN	Color	Wavelength $\lambda$ (nm)/ CIE (x,y)	Lens Type	Typ. Luminous Intensity $I_v$ (mcd)	Viewing Angle (deg.)	Typ. Forward Voltage $V_F$ (V)	Forward Current $I_F$ (mA)
LS193HBCT-5A	● Blue	466	Water Clear	15	120	2.7	5
LS193LGCT-5A	● Green	520		2.9			
LS193KGCT-XG	● Yellow Green	571		30		2.1	20
LS193JYCT-5A	● Yellow	590		120		2.0	5
LS193JFCT-S60	● Orange	605		120		2.1	20
LS193SRCT-XG	● Super Red	624		100		2.0	20
LS193WDT-5A	○ White	(0.27, 0.28)		Yellow Diffused		200	2.8

1204 (LS110) Dimension 3.2\*1.0\*1.5 mm



Specifications

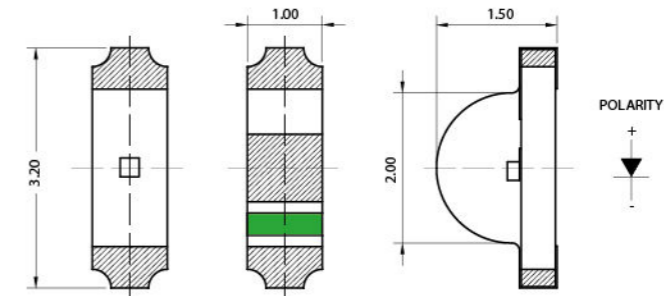

Ref. PN	Color	Wavelength $\lambda$ (nm)/ CIE (x,y)	Lens Type	Typ. Luminous Intensity $I_v$ (mcd)	Viewing Angle (deg.)	Typ. Forward Voltage $V_F$ (V)	Forward Current $I_F$ (mA)
LS110LBCT	● Blue	470	Water Clear	120	130	3.3	20
LS110LGCT	● Green	525		300		3.1	
LS110JGCT	● Yellow Green	570		50		2.05	
LS110JYCT	● Yellow	590		70		2.05	
LS110JFCT	● Super Amber	605		120		2.0	
LS110JRCT	● Super Red	631		60		1.9	
LS110WDT-LCFC	○ White	(0.27, 0.26)		Yellow Diffused		112	

1204 (LS111) Dimension 3.0\*1.0\*2.0 mm



Specifications

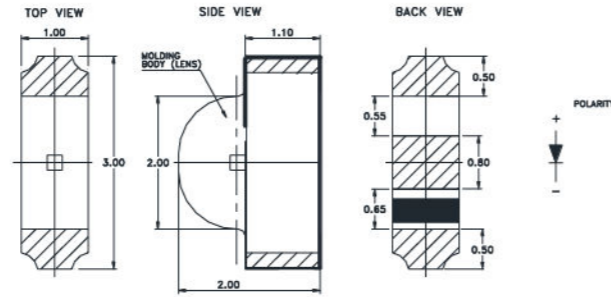

Ref. PN	Color	Wavelength $\lambda$ (nm)/ CIE (x,y)	Lens Type	Typ. Luminous Intensity $I_v$ (mcd)	Viewing Angle (deg.)	Typ. Forward Voltage $V_F$ (V)	Forward Current $I_F$ (mA)
LS111LBCT-5A	Blue	465	Water Clear	50	130	2.8	5
LS111LGCT-5A	Green	527		280		2.6	
LS111KGCT-5A	Yellow Green	570		10		1.85	
LS111KYCT-5A	Yellow	590		25		1.9	
LS111KFCT-5A	Amber	605		30		1.9	
LS111KRCT-5A	Red	632		25		1.85	
LS111WDT-5A	White	(0.28, 0.28)		Yellow Diffused		280	

0802 (LS171) Dimension 2.1\*0.6\*1.0 mm



Specifications

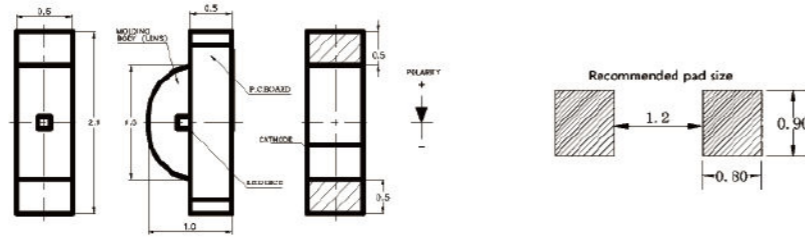

Ref. PN	Color	Wavelength $\lambda$ (nm)/ CIE (x,y)	Lens Type	Typ. Luminous Intensity $I_v$ (mcd)	Viewing Angle (deg.)	Typ. Forward Voltage $V_F$ (V)	Forward Current $I_F$ (mA)
LS171LBCT	Blue	468	Water Clear	120	120	3.0	20
LS171LGCT	Green	525		600		3.0	
LS171JGCT	Yellow Green	570		40		2.0	
LS171JYCT	Yellow	590		110		2.0	
LS171JFCT	Orange	605		120		2.0	
LS171KRCT	Super Red	625		140		2.0	
LS171WDT-5A	White	(0.27, 0.30)		Yellow Diffused		180	

1204 (LS115) Dimension 3.2\*1.0\*1.5 mm

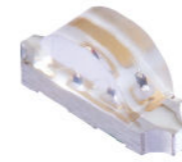

Specifications

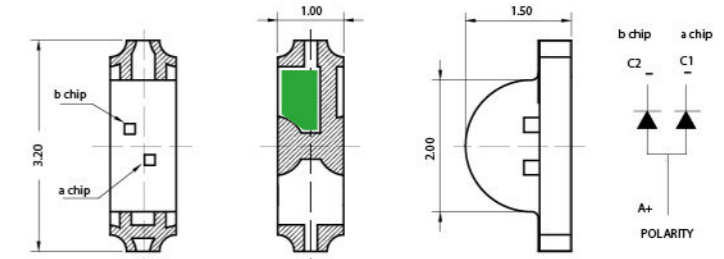

Ref. PN	Color	Wavelength $\lambda$ (nm)/ CIE (x,y)	Lens Type	Typ. Luminous Intensity $I_v$ (mcd)	Viewing Angle (deg.)	Typ. Forward Voltage $V_F$ (V)	Forward Current $I_F$ (mA)
LS115JRJGCT-5A	Super Red	630	Water Clear	15	130	1.8	5
	Yellow Green	570		8		1.95	
LS115JFLGCT	Orange	605		100		2.0	
	Green	525		600		3.1	
LS115JFJGCT	Super Amber	605		112		2.0	
	Yellow Green	570		28		2.0	
LS115KFLBCT	Super Amber	605		180		2.0	
	Blue	470	150	3.0			
LS115JFWDT-LCFC	Super Amber	605	Yellow Diffused	18	130	2.0	5
	White	(0.27, 0.255)		71.5		2.8	

3010 (LS116) Dimension 3.0\*1.0\*2.0 mm



Specifications

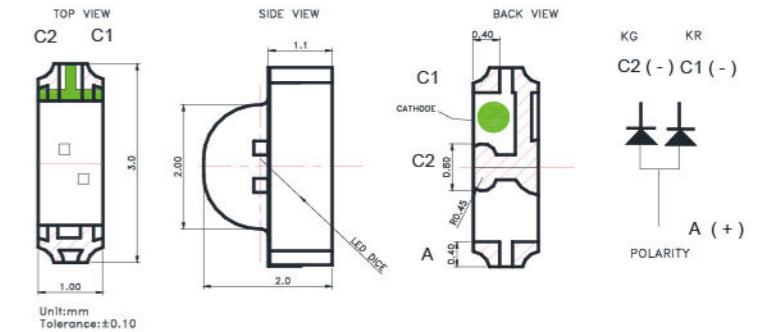

Ref. PN	Color	Wavelength $\lambda$ (nm)/ CIE (x,y)	Lens Type	Typ. Luminous Intensity $I_v$ (mcd)	Viewing Angle (deg.)	Typ. Forward Voltage $V_F$ (V)	Forward Current $I_F$ (mA)
LS116KYTBCT-ZX	Yellow	590	Water Clear	112	130	1.9	20
	Blue	470				3.4	
LS116KYKGCT-ZX	Yellow	589		112		1.9	
	Green	571		71		2.0	
LS116KRKGCT-ZX	Red	631		45		1.9	
	Green	571		45		2.0	
LS116JYJGCT-ZX	Yellow	589		38		2.0	
	Yellow Green	573	19	2.0			

1204 (LS11F) Dimension 3.2\*1.0\*1.5 mm

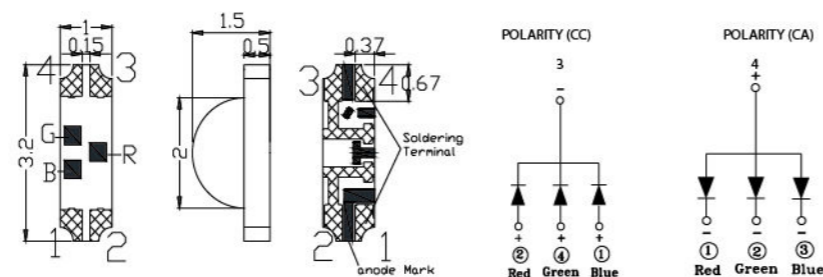
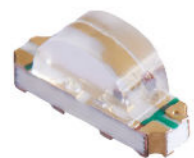

Specifications

Ref. PN	Color	Wavelength $\lambda$ (nm)/ CIE (x,y)	Lens Type	Typ. Luminous Intensity $I_v$ (mcd)	Viewing Angle (deg.)	Typ. Forward Voltage $V_F$ (V)	Forward Current $I_F$ (mA)
LS11F1RGBCT-CC	● Super Red	623	Water Clear	180	130	1.9	10
	● Green	525		3.1			
	● Blue	470		3.1			
LS11F1RGBCT-CA-XM	● Super Red	623	Water Clear	180	130	2.0	20
	● Green	520		3.1			
	● Blue	465		3.1			

0603 (LC19D) Dimension 1.6\*0.8\*0.9 mm

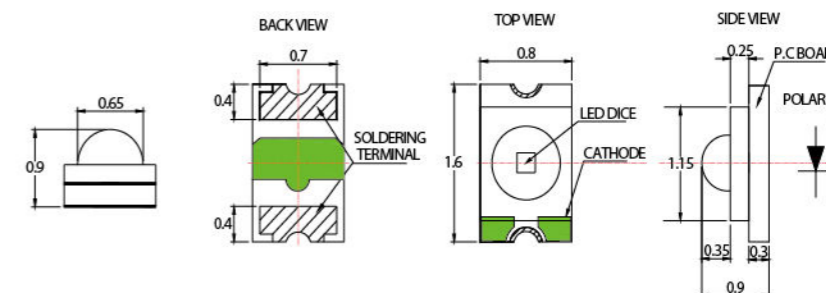

Specifications

Ref. PN	Color	Wavelength $\lambda$ (nm)/ CIE (x,y)	Lens Type	Typ. Luminous Intensity $I_v$ (mcd)	Viewing Angle (deg.)	Typ. Forward Voltage $V_F$ (V)	Forward Current $I_F$ (mA)
LC19DLBCT-2mA-XG	● Blue	469	Water Clear	80	60	2.6	2
LC19DLGCT-2mA-XG	● Green	530		310		2.5	
LC19DGCT-2mA-XG	● Yellow Green	571		20		1.9	
LC19DJYCT-2mA-XG	● Yellow	593		60		1.9	
LC19DJECT-2mA-XG	● Super Amber	605		80		1.9	
LC19DJRCT-2mA-XG	● Red	623		80		1.9	
LC19DLBCT-XG	● Blue	466		430		3.0	
LC19DLGCT-XG	● Green	525		1500		3.0	
LC19DKGCT-XG	● Yellow Green	571		200		2.0	
LC19DKYCT-XG	● Yellow	593		500		2.0	
LC19DJECT-XG	● Super Amber	605	440	2.0			
LC19DJRCT-XG	● Red	624	440	2.0			



# PLCC Series Applications

- ◆ Wearable device
- ◆ Mobile device
- ◆ Medical device
- ◆ Control panel
- ◆ IoT equipment
- ◆ TV backlight
- ◆ LED lighting



1808 (LT1808) Dimension 1.8\*0.8\*0.5 mm

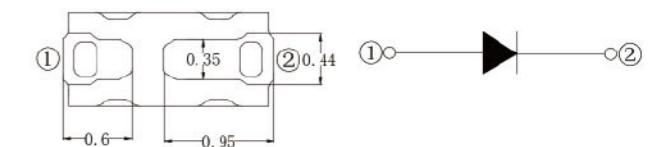
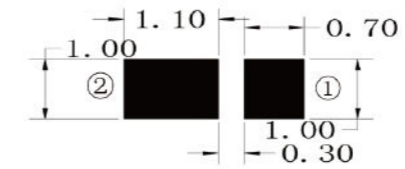
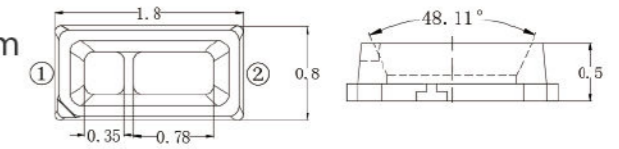

## Specifications

Ref. PN	Color	Wavelength $\lambda_d$ (nm)/ CIE (x,y)	Lens Type	Typ. Luminous Intensity $I_v$ (mcd)	Viewing Angle (deg.)	Typ. Forward Voltage $V_f$ (V)	Forward Current $I_f$ (mA)
LT1808LBCT	Blue	470	Water Clear	650	120	2.8	20
LT1808LGCT	Green	525		1500		3.0	
LT1808JYCT	Yellow	590		160			
LT1808KGCT	Yellow Green	573		60		2.0	
LT1808KRCT	Red	620		300		3.0	
LT1808WDT-CW	White	(0.31, 0.34)		2500			

3020 (LC650WDT) Dimension 3.0\*2.0\*1.3 mm

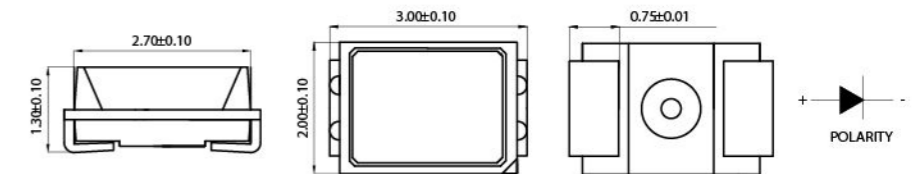

## Specifications

Ref. PN	Color	Wavelength $\lambda_d$ (nm)/ CIE (x,y)	Lens Type	Typ. Luminous Intensity $I_v$ (mcd)	Viewing Angle (deg.)	Typ. Forward Voltage $V_f$ (V)	Forward Current $I_f$ (mA)
LT650WDT		(0.30, 0.29)		2600		2.9	
LT650WDT-NW	White	5300 ~ 6100 K	Yellow Diffused	10 lm	120	3.0	20
LT650WDT-WW		3500 ~ 4000 K		12 lm		2.9	

2835 Series

Dimension 2.8\*3.5\*0.8 mm

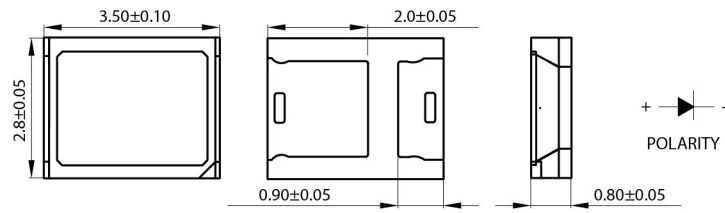

Specifications

Ref. PN	Color	Wavelength $\lambda$ (nm)/ CIE (x,y)	Lens Type	Typ. Luminous Intensity $I_v$ (lm)	Viewing Angle (deg.)	Typ. Forward Voltage $V_F$ (V)	Forward Current $I_F$ (mA)
LT2835WDT-CW	○ White	6300 ~ 6800 K	Yellow Diffused	28 lm	120	3.0	60
LT2835WDT-NW		3800 ~ 4200 K		34 lm		2.8	
LT2835WDT-WW		2900 ~ 3200 K		30 lm		3.0	
LT2835WDT-CW		5500 ~ 6000 K		80 lm			
LT2835WDT-NW		3800 ~ 4200 K		75 lm			
LT2835WDT-WW		2900 ~ 3200 K		70 lm		150	

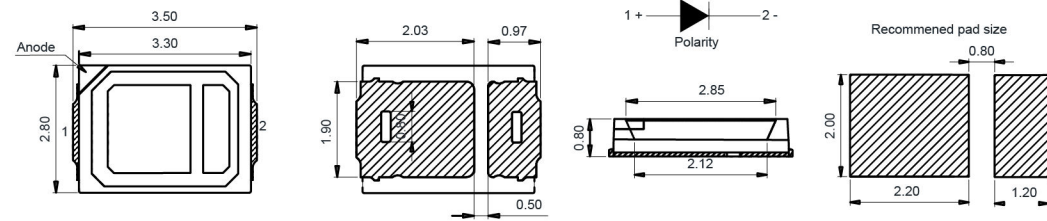

Specifications

Ref. PN	Color	Wavelength $\lambda$ (nm)/ CIE (x,y)	Lens Type	Typ. Luminous Intensity $I_v$ (mcd)	Viewing Angle (deg.)	Typ. Forward Voltage $V_F$ (V)	Forward Current $I_F$ (mA)	
LT2835KRCT	● Red	622	Water Clear	9	120	2.0	60	
LT2835LBCT	● Blue	460		5		3.0		
LT2835KYCT	● Yellow	590		9		2.3		
LT2835KRCT	● Red	625		19		2.0		150
LT2835LBCT	● Blue	455		12		3.0		

3014 Series Dimension 3.0\*1.4\*0.7 mm

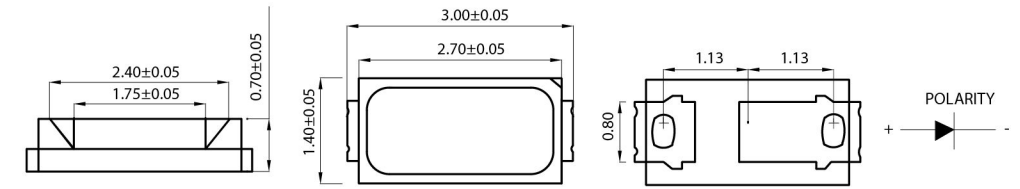

Specifications

Ref. PN	Color	Wavelength $\lambda$ (nm)/ CIE (x,y)	Lens Type	Typ. Luminous Intensity $I_v$ (mcd)	Viewing Angle (deg.)	Typ. Forward Voltage $V_F$ (V)	Forward Current $I_F$ (mA)
LT3014CWDT	○ White	9000 ~ 12000 K	Yellow Diffused	14 lm	120	2.9	30
LT3014NWDT		4800 ~ 5200 K		10 lm		3.0	20
LT3014WWDT		2900 ~ 3100 K		2400		2.8	

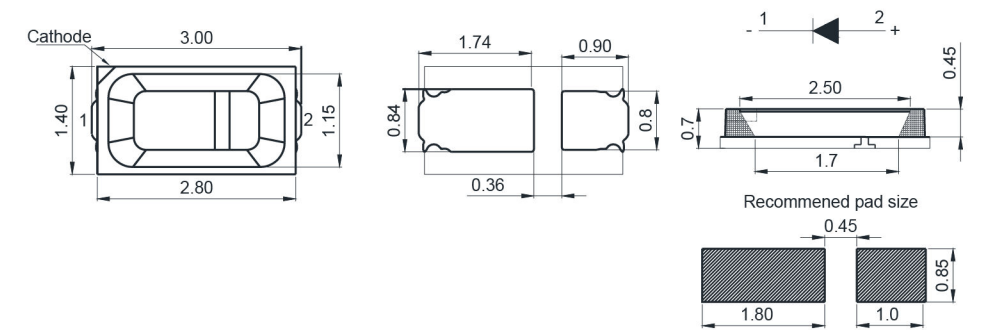

Specifications

Ref. PN	Color	Wavelength $\lambda$ (nm)/ CIE (x,y)	Lens Type	Typ. Luminous Intensity $I_v$ (mcd)	Viewing Angle (deg.)	Typ. Forward Voltage $V_F$ (V)	Forward Current $I_F$ (mA)
LT3014KRCT	● Red	620	Water Clear	60	120	1.8	5
LT3014KGCT	● Yellow Green	569		20		2.0	
LT3014KYCT	● Yellow	590		600		20	

3528 Series Dimension 3.5\*2.8\*1.9 mm

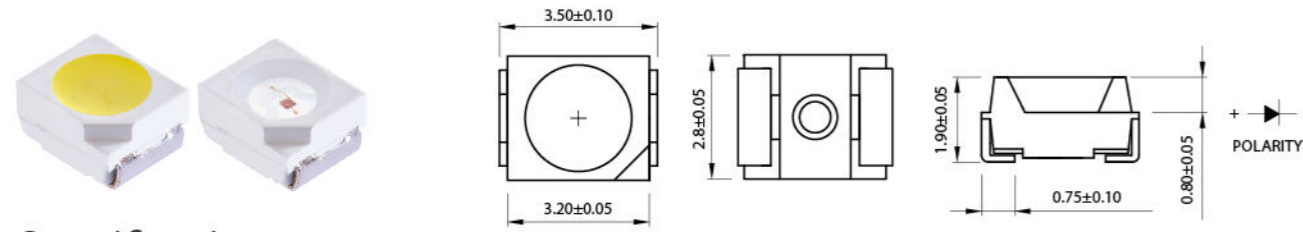

Specifications

Ref. PN	Color	Wavelength λd(nm)/ CIE (x,y)	Lens Type	Typ. Luminous Intensity I <sub>v</sub> (mcd)	Viewing Angle (deg.)	Typ. Forward Voltage V <sub>F</sub> (V)	Forward Current I <sub>F</sub> (mA)
LT670WDT-UV-CW-B-S3	○ White	6300 ~ 6800 K	Yellow Diffused	2500	120	3.0	20
LT670WDT-WW-B-S3		1600 ~ 1700 K		1500		2.9	



Ref. PN	Color	Wavelength λd(nm)/ CIE (x,y)	Lens Type	Typ. Luminous Intensity I <sub>v</sub> (mcd)	Viewing Angle (deg.)	Typ. Forward Voltage V <sub>F</sub> (V)	Forward Current I <sub>F</sub> (mA)
LT670LBCT	● Blue	465	Water Clear	90	120	2.6	5
LT670LGCT	● Green	520		2000		3.0	
LT670KGCT	● Yellow Green	570		100		2	
LT670KYCT	● Yellow	590		200		2.0	20
LT670KFCT	● Super Amber	604		220		2.0	
LT670KRCT	● Super Red	622		300		2.0	

3528 Series Dimension 3.5\*2.8\*1.9 mm

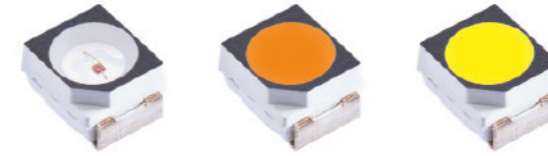

Specifications

Ref. PN	Color	Wavelength λd(nm)/ CIE (x,y)	Lens Type	Typ. Luminous Intensity I <sub>v</sub> (mcd)	Viewing Angle (deg.)	Typ. Forward Voltage V <sub>F</sub> (V)	Forward Current I <sub>F</sub> (mA)
LT670LBCT-UV-B	● Blue	465	Water Clear	500	120	3.0	20
LT670KGCT-UV-B	● Green	525		1600		3.0	
LT670KRCT-UV-B	● Red	625		800		2.0	
LT670XYCT-UV-B	● Amber	590		800		2.0	
LT670WDT-UV-WW-B	● Warm White	1600 ~ 1700		1500		2.9	
LT670WDT-UV-CW-B	○ Cold white	6300 ~ 6800		2500		3.0	

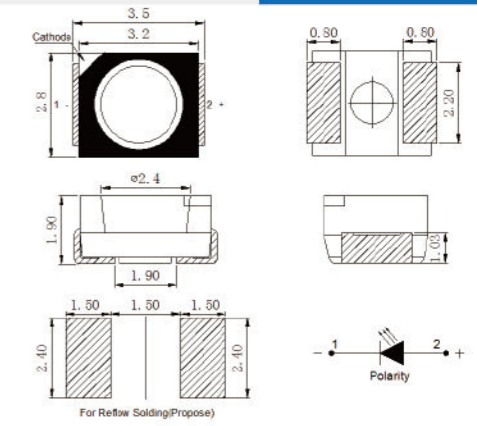

3535 (LT3535) Dimension 3.5\*3.5\*2.05 mm

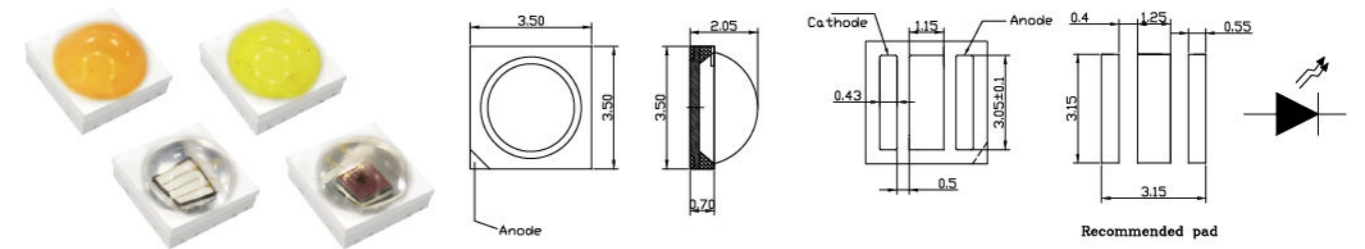

Specifications

Ref. PN	Color	Wavelength λd(nm)/ CIE (x,y)	Lens Type	Typ. Luminous Intensity I <sub>v</sub> (mcd)	Viewing Angle (deg.)	Typ. Forward Voltage V <sub>F</sub> (V)	Forward Current I <sub>F</sub> (mA)
LT3535LBCT	● Blue	470	Water Clear	45	120	3.1	350
LT3535LGCT	● Green	525		100		3.2	
LT3535KRCT	● Red	621		70		2.3	
LT3535YWCT	● Amber	(0.56, 0.44)		110		3.1	
LT3535WCT	○ White	6300 K		150		3.0	

3528 Series Dimension 3.5\*2.8\*1.9 mm

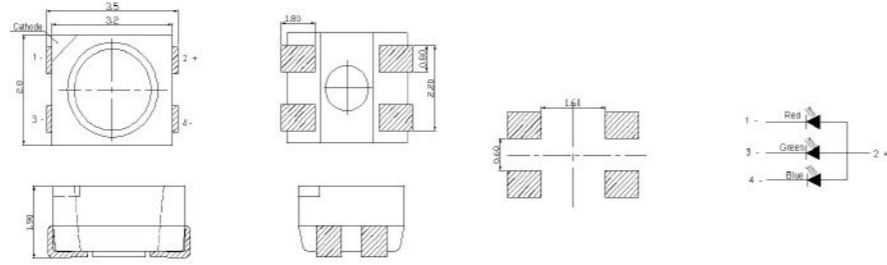

Specifications

Ref. PN	Color	Wavelength $\lambda_d$ (nm)/ CIE (x,y)	Lens Type	Typ. Luminous Intensity $I_v$ (mcd)	Viewing Angle (deg.)	Typ. Forward Voltage $V_f$ (V)	Forward Current $I_f$ (mA)
LT67FRGBCT-4PIN-BKS	Red	625	Water Clear	700	120	2.0	20
	Green	520		3.0			
	Blue	470		3.0			

Dimension 3.5\*2.8\*1.8 mm

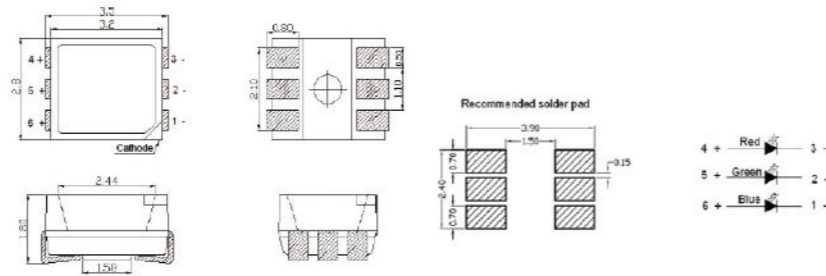

Ref. PN	Color	Wavelength $\lambda_d$ (nm)/ CIE (x,y)	Lens Type	Typ. Luminous Intensity $I_v$ (mcd)	Viewing Angle (deg.)	Typ. Forward Voltage $V_f$ (V)	Forward Current $I_f$ (mA)
LT67FRGBCT-BKS	Red	625	Water Clear	1500	120	2.0	40
	Green	525		2.8			
	Blue	468		3.0			

5050 (LT69FRGB) Dimension 5.0\*5.0\*1.5 mm

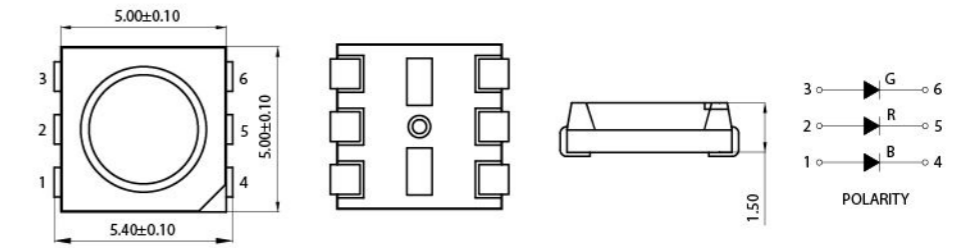

Specifications

Ref. PN	Color	Wavelength $\lambda_d$ (nm)/ CIE (x,y)	Lens Type	Typ. Luminous Intensity $I_v$ (mcd)	Viewing Angle (deg.)	Typ. Forward Voltage $V_f$ (V)	Forward Current $I_f$ (mA)
LT69FRGBCT	Super Red	625	Water Clear	800	120	2.0	20
	Green	525		2000		3.0	
	Blue	470		400		3.0	

LS020 Series Dimension 0.7\*4.5\*1.0 mm

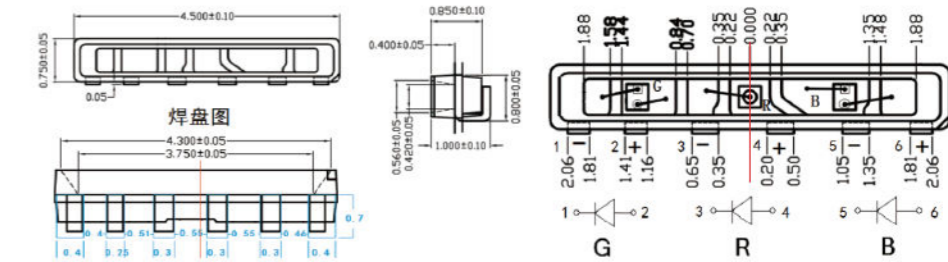

Specifications

Ref. PN	Color	Wavelength $\lambda_d$ (nm)/ CIE (x,y)	Lens Type	Typ. Luminous Intensity $I_v$ (mcd)	Viewing Angle (deg.)	Typ. Forward Voltage $V_f$ (V)	Forward Current $I_f$ (mA)
LS020GRBCT-HH	Red	622	Water Clear	600	120	2.0	20
	Green	520		1300		3.0	
	Blue	469		500		3.0	



## 2835 Dimension 2.8\*3.5\*2.18 mm

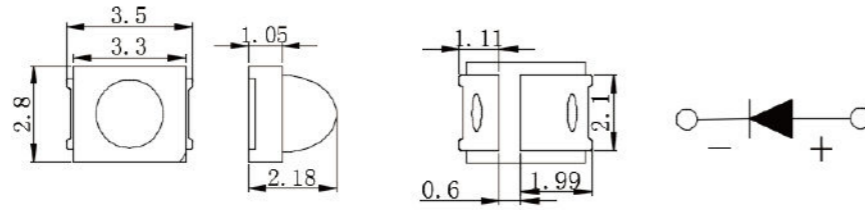

### Specifications

Ref. PN	Color	Wavelength $\lambda_d$ (nm)/ CIE (x,y)	Lens Type	$I_e$ (mw/sr)	Viewing Angle (deg.)	Typ. Forward Voltage $V_f$ (V)	Forward Current $I_f$ (mA)
LT2835IR4CT-30				80	30	1.3	100
LT2835IR4CT-60	IR	850	Water Clear	45	60	1.4	
LT2835IR4CT-90				85	90	1.6	150