

# DATA SHEET

PART NO. : LS020WDT-CW2-S59

REV: A / 0

CUSTOMER'S APPROVAL : \_\_\_\_\_

DCC : \_\_\_\_\_

DRAWING NO. : DS-51-25-016

DATE : 2025-02-26

PAGE

1 of 12

# SURFACE MOUNT DEVICE LED

Part No. : LS020WDT-CW2-S59

REV: A / 0

## ● PACKAGE OUTLINE DIMENSIONS

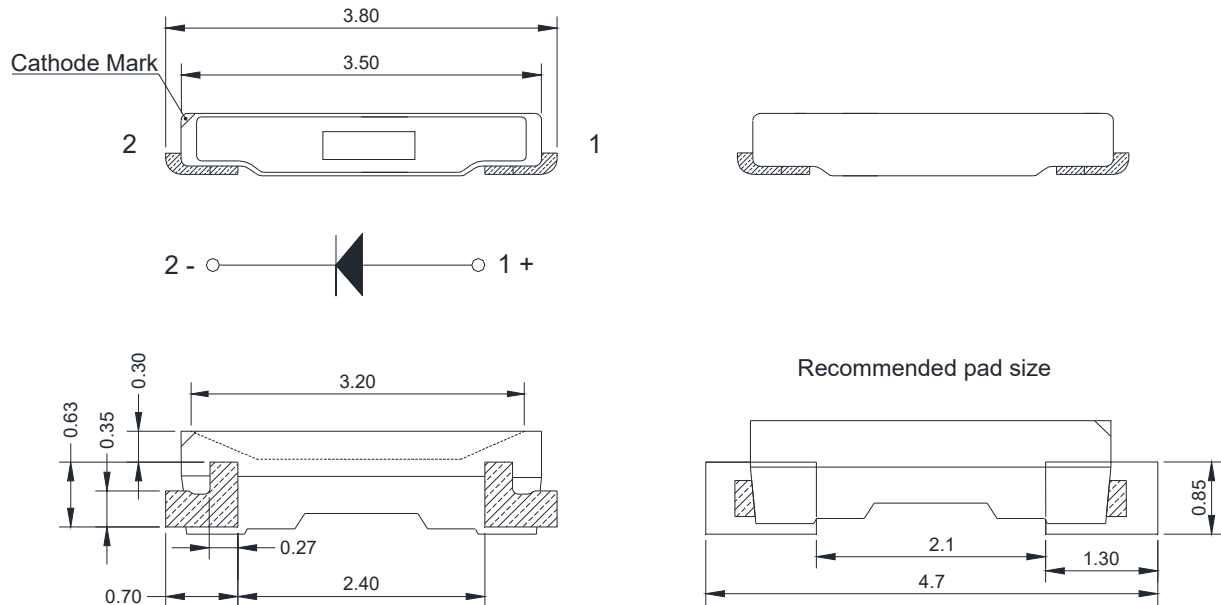

### Notes:

1. All dimensions are in millimeters.
2. Tolerance is  $\pm 0.1\text{mm}$  (.004") unless otherwise noted.

## ● Features

- \* Side looking special for LCD backlight.
- \* Package in 8mm tape on 7" diameter reels.
- \* Compatible with automatic Pick & Place equipment.
- \* Compatible with Infrared and Wave soldering reflow solder processes.
- \* EIA STD package.
- \* I.C. compatible.
- \* Pb free product.
- \* Meet RoHS Green Product.
- \* Moisture sensitivity level: 3

# SURFACE MOUNT DEVICE LED

Part No. : LS020WDT-CW2-S59

REV: A / 0

## ● Chip Materials

- \* Dice Material : InGaN
- \* Light Color : White light
- \* Lens Color : Yellow Diffused

## ● Absolute Maximum Ratings(Ta=25°C)

Symbol	Parameter	Rating	Unit
P <sub>D</sub>	Power Dissipation	98	mW
IFP	Peak Forward Current (1/10 Duty Cycle, 0.1ms Pulse Width)	100	mA
I <sub>F</sub>	Continuous Forward Current	30	mA
V <sub>R</sub>	Reverse Voltage	5	V
Topr	Operating Temperature Range	-40 ~ +85	°C
Tstg	Storage Temperature Range	-40 ~ +100	°C

HBM : Human Body Model. Seller gives no other assurances regarding the ability of to withstand ESD.

## ● Electro-Optical Characteristics(Ta=25°C)

Parameter	Symbol	Min	Typ	Max	Unit	Test Condition
Luminous Intensity	IV	8.5	-	10.5	lm	IF=20mA
Viewing Angle	2θ1/2	-	120	-	deg	IF=20mA
Color Temperature for white	CCT	-	25000	-	K	IF=20mA
Chromaticity Coordinates	X	-	0.295	-	-	IF=20mA
	Y	-	0.300	-	-	
Color rendering index	CRI	65	-	-	Ra	IF=20mA
Forward Voltage	VF	2.8	3.0	3.2	V	IF=20mA
Reverse Current	IR	-	-	5	μA	VR = 5V

# SURFACE MOUNT DEVICE LED

Part No. : LS020WDT-CW2-S59

REV: A / 0

## ●Bin Code List

Luminous Intensity(Iv),Unit: mcd/lm@20mA

Bin Code	Min(mcd)	Max(mcd)	Min(lm)	Max(lm)
26D	2550	2700	8.5	9.0
27D	2700	2850	9.0	9.5
28D	2850	3000	9.5	10.0
29D	3000	3150	10.0	10.5

Tolerance of each bin are±15%

Forward Voltage(VF), Unit:V @20mA

Bin Code	Min	Max
V28	2.80	2.90
V29	2.90	3.00
V30	3.00	3.10
V31	3.10	3.20

Tolerance of each bin are±0.1V

## Color Bins

Bin	X	Y	Bin	X	Y	Bin	X	Y	Bin	X	Y
H1	0.2566	0.2169	H2	0.2635	0.2299	H3	0.2704	0.2429	H4	0.2773	0.2559
	0.2635	0.2299		0.2704	0.2429		0.2773	0.2559			
	0.2671	0.2281		0.2740	0.2411		0.2809	0.2541			
	0.2602	0.2151		0.2671	0.2281		0.2740	0.2411			

Tolerance of measurement of Chromatic coordinates is ±0.01

# SURFACE MOUNT DEVICE LED

Part No. : LS020WDT-CW2-S59

REV: A / 0

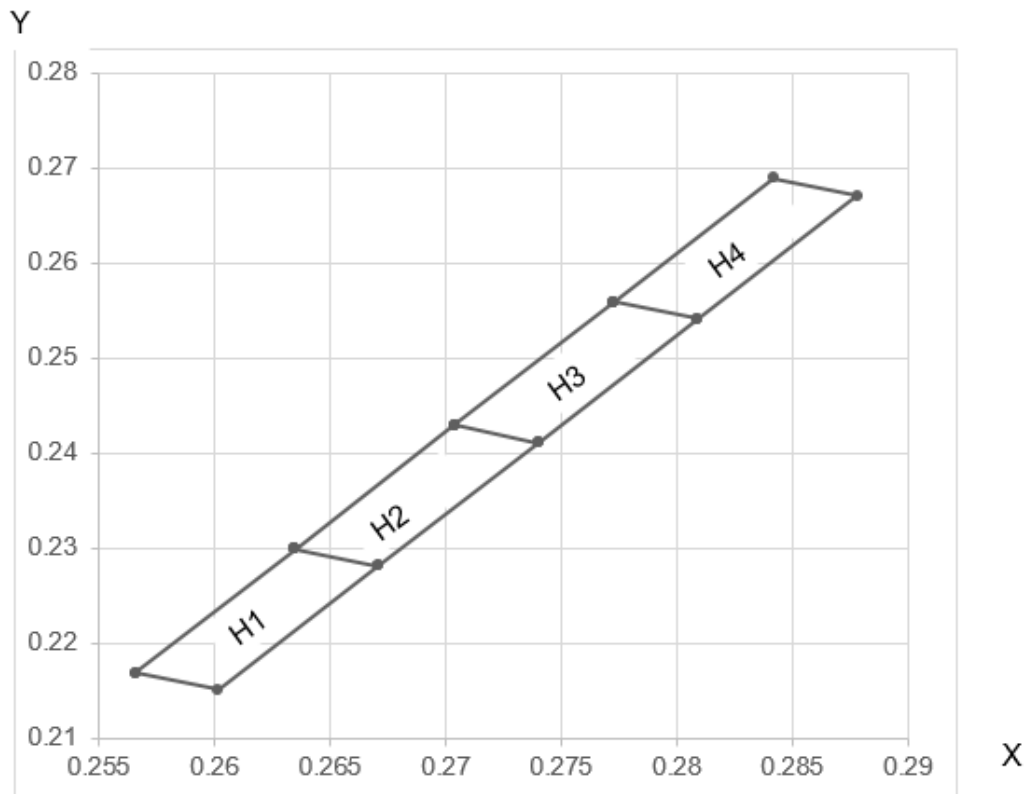

## Notes:

1. Luminous intensity is measured with a light sensor and filter combination that approximates the CIE eye-response curve.
2.  $2\theta_{1/2}$  is the off-axis angle at which the luminous intensity is half the axial luminous intensity.
3. The dominant wavelength  $\lambda_d$  is derived from the CIE chromaticity diagram and represents the single wavelength which defines the color of the device.
4. Caution in ESD:  
Static Electricity and surge damages the LED. It is recommended use a wrist band or anti-electrostatic glove when handling the LED. All devices, equipment and machinery must be properly grounded.
5. Major standard testing equipment by "Instrument System" Model: CAS140B Compact Array Spectrometer and "KEITHLEY" Source Meter Model: 2400.

# SURFACE MOUNT DEVICE LED

Part No. : LS020WDT-CW2-S59

REV: A / 0

## ● Typical Electro-Optical Characteristics Curves

Relative intensity VS wavelength

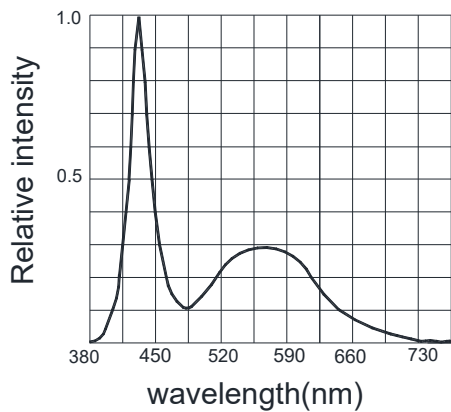

Current and ambient temperature

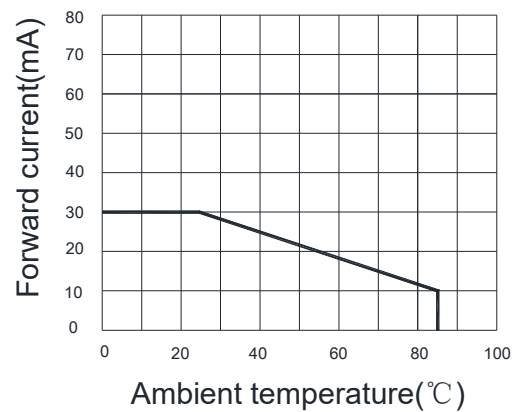

Voltage current relationship

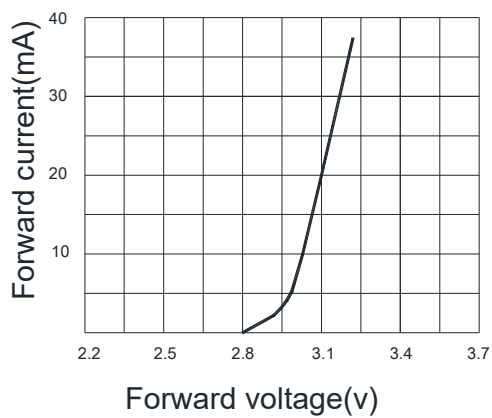

Relative light intensity vs ambient temperature

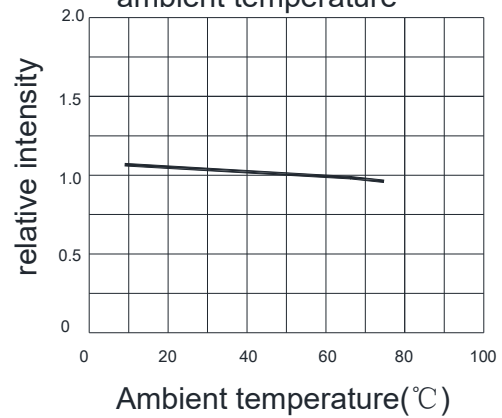

Relative light intensity vs current

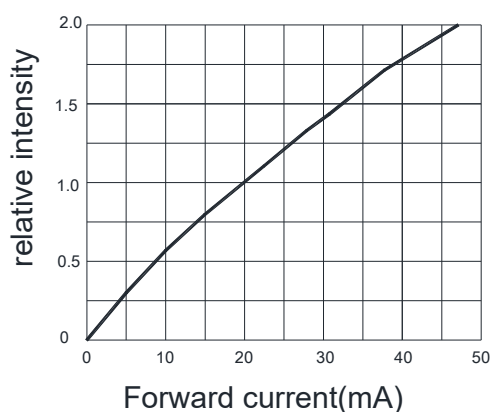

Radiation angle

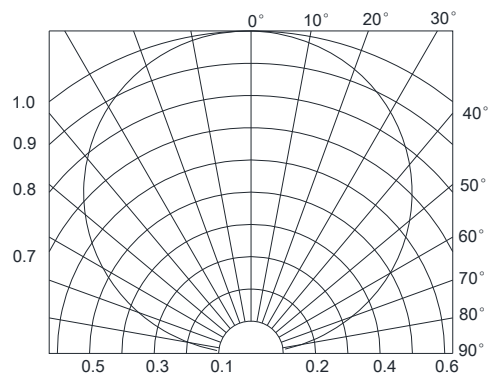

# SURFACE MOUNT DEVICE LED

Part No. : LS020WDT-CW2-S59

REV: A / 0

## ● Label Explanation

CUS.PART NO:

CUSTOMER:

PART NO:



LOT NO:



QUANTITY:



DATE CODE:



IV:

VF:

WD:

QC:

GPRoH\$

ITEM CODE: PARRA LIGHT

PART NO: LS020WDT-CW2-S59

IV --- Luminous Intensity Code

LOT NO: EN S L 12 09 0110  
          A    B    C    D    E

A---EN: Emos Code

B---S: SMD

L---Local

D---Year

E---Month

F---SPEC.

PACKING QUANTITY OF BAG :

3000pcs for 150、170、110、155、115 series

4000pcs for 191 series

5000pcs for 192 series

DATE CODE: 2012 09 10  
              G    H    I

G--- Year

H--- Month

I --- Day

# SURFACE MOUNT DEVICE LED

Part No. : LS020WDT-CW2-S59

REV: A / 0

## ● Reel Dimensions

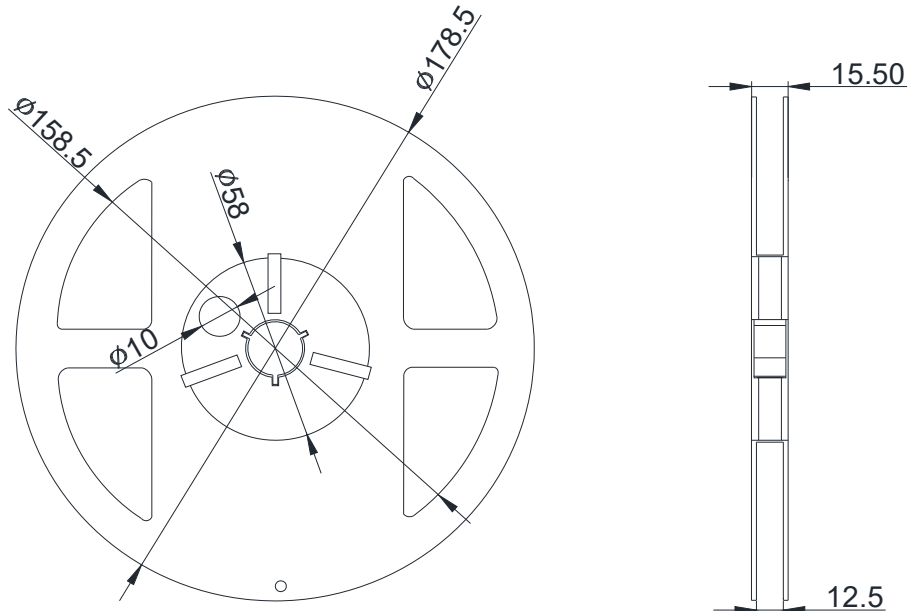

### Notes:

1. Taping Quantity :5000pcs
2. The tolerances unless mentioned is  $\pm 0.1$ mm, Angle  $\pm 0.5^\circ$ , Unit : mm.

## ● Package Dimensions Of Tape And Reel

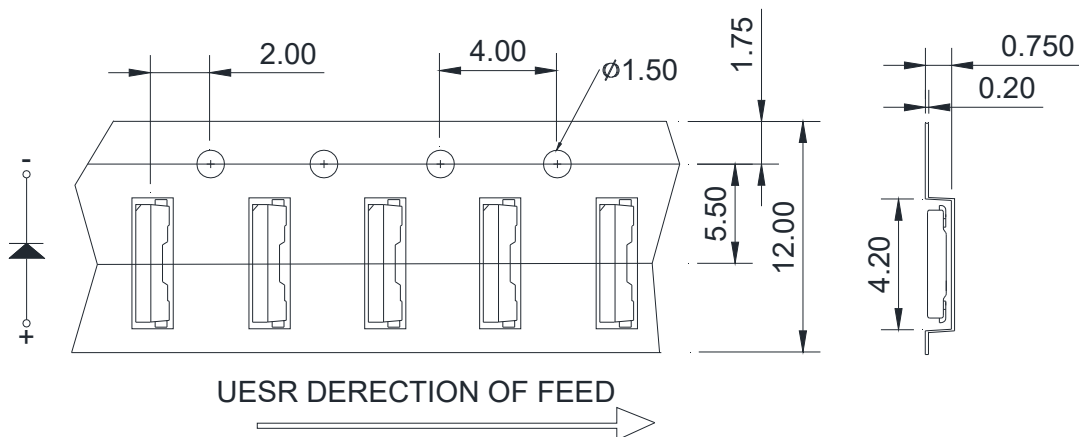

Notes: All dimensions are in millimeters.

# SURFACE MOUNT DEVICE LED

Part No. : LS020WDT-CW2-S59

REV: A / 0

## ● Cleaning

- \* If cleaning is required , use the following solutions for less than 1 minute and less than 40°C.
- \* Appropriate chemicals: Ethyl alcohol and isopropyl alcohol.
- \* Effect of ultrasonic cleaning on the LED resin body differs depending on such factors as the oscillator output, size of PCB and LED mounting method. The use of ultrasonic cleaning should be enforced at proper output after confirming there is no problem.

## ● Suggest Soldering Pad Dimensions

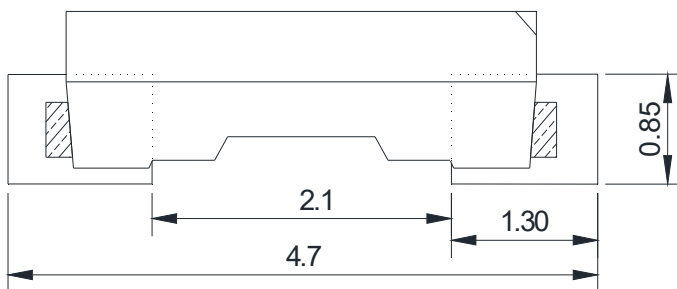

Direction of PWB camber  
and go to reflow furnace

# SURFACE MOUNT DEVICE LED

Part No. : LS020WDT-CW2-S59

REV: A / 0

## ● Suggest Sn/Pb IR Reflow Soldering Profile Condition:

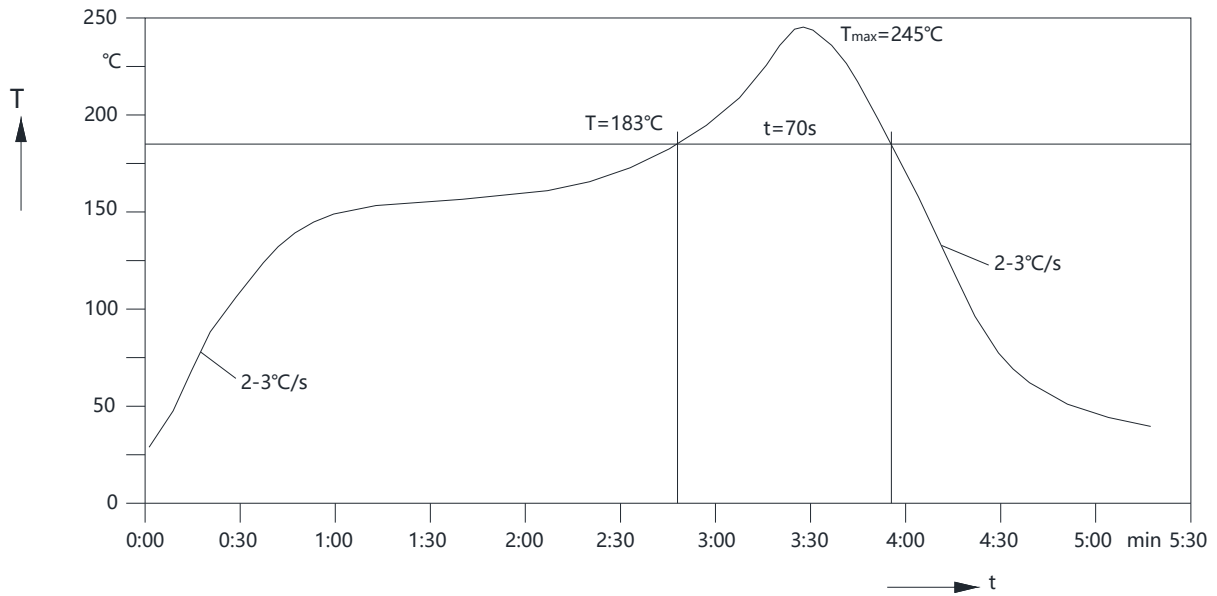

## ● Suggest Pb-Free IR Reflow Soldering Profile Condition:

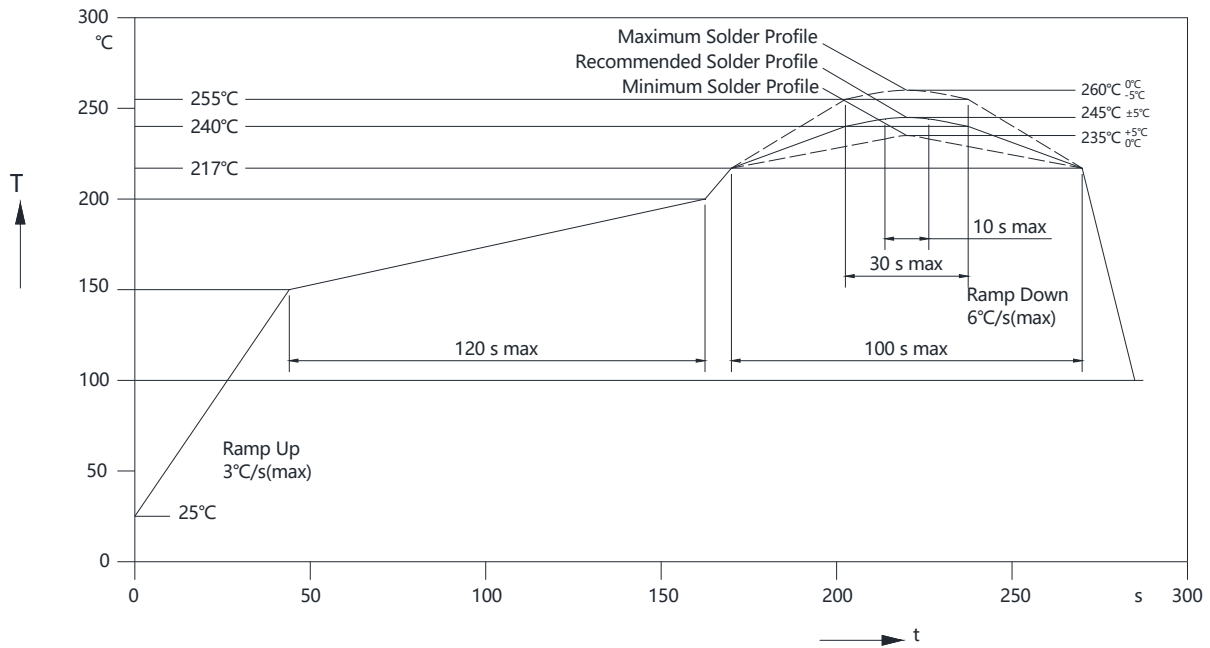

# SURFACE MOUNT DEVICE LED

Part No. : LS020WDT-CW2-S59

REV: A / 0

## ● CAUTIONS

### 1. Application Limitation :

The LED's described here are intended to be used for ordinary electronic equipment (such as office equipment, communication equipment and household application). Consult PARA's sales in advance for information on application in which exceptional quality and reliability are required, particularly when the failure or malfunction of the LED's may directly jeopardize life or health (such as airplanes, automobiles, traffic control equipment, life support system and safety devices).

### 2. Storage

Do not open moisture proof bag before the products are ready to use.

Before opening the package: The LEDs should be kept at 30°C or less and 90%RH or less.

If the moisture absorbent material (silica gel) has faded away or the LEDs have exceeded the storage time, baking treatment should be performed using the following conditions.

Baking treatment: 60±5°C for 24 hours.

### 3. Soldering

Do not apply any stress to the lead frame during soldering while the LED is at high temperature. Recommended soldering condition.

Reflow Soldering :

Pre-heat 120~150°C, 120sec. MAX., Peak temperature : 240°C Max. Soldering time : 10 sec Max.

Soldering Iron : (Not recommended)

Temperature 300°C Max., Soldering time : 3 sec. Max.(one time only), power dissipation of iron : 20W Max. use SN60 solder of solder with silver content and don't to touch LED lens when soldering.

Wave soldering :

Pre-heat 100°C Max, Pre-heat time 60 sec. Max, Solder wave 260°C Max, Soldering time 5 sec. Max. performed consecutively cooling process is required between 1<sup>st</sup> and 2<sup>nd</sup> soldering processes.

# SURFACE MOUNT DEVICE LED

Part No. : LS020WDT-CW2-S59

REV: A / 0

## 4. Lead-Free Soldering

For Reflow Soldering :

- 1、 Pre-Heat Temp:150-180°C,120sec.Max.
- 2、 Soldering Temp:Temperature Of Soldering Pot Over 230°C,40sec.Max.
- 3、 Peak Temperature:260°C , 5sec.
- 4、 Reflow Repetition:2 Times Max.
- 5、 Suggest Solder Paste Formula 93.3 Sn/3.1 Ag/3.1 Bi /0.5 Cu

For Soldering Iron (Not Recommended) :

- 1、 Iron Tip Temp:350°C Max.
- 2、 Soldering Iron:30w Max.
- 3、 Soldering Time:3 Sec. Max. One Time.

For Dip Soldering :

- 1、 Pre-Heat Temp:150°C Max. 120 Sec. Max.
- 2、 Bath Temp:265°C Max.
- 3、 Dip Time:5 Sec. Max.

## 5. Drive Method

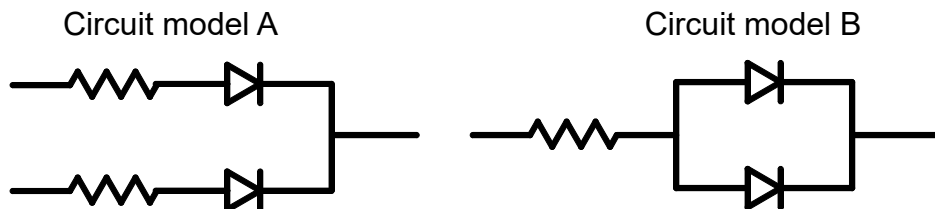

(A)Recommended circuit.

(B)The difference of brightness between LED`s could be found due to the Vf-If characteristics of LED.