



PARA LIGHT ELECTRONICS CO., LTD.

11F, No.8, Jiankang Rd,Zhonghe Dist,New Taipei City 253, Taiwan

Tel: 886-2-2225-3733

Fax: 886-2-2225-4800

E-mail: para@para.com.tw

<http://www.para.com.tw>

DATA SHEET

PART NO. : L-S153PTDT-Lens-RB

REV : A / 1

CUSTOMER'S APPROVAL : _____

DCC : _____

PACKAGE DIMENSIONS

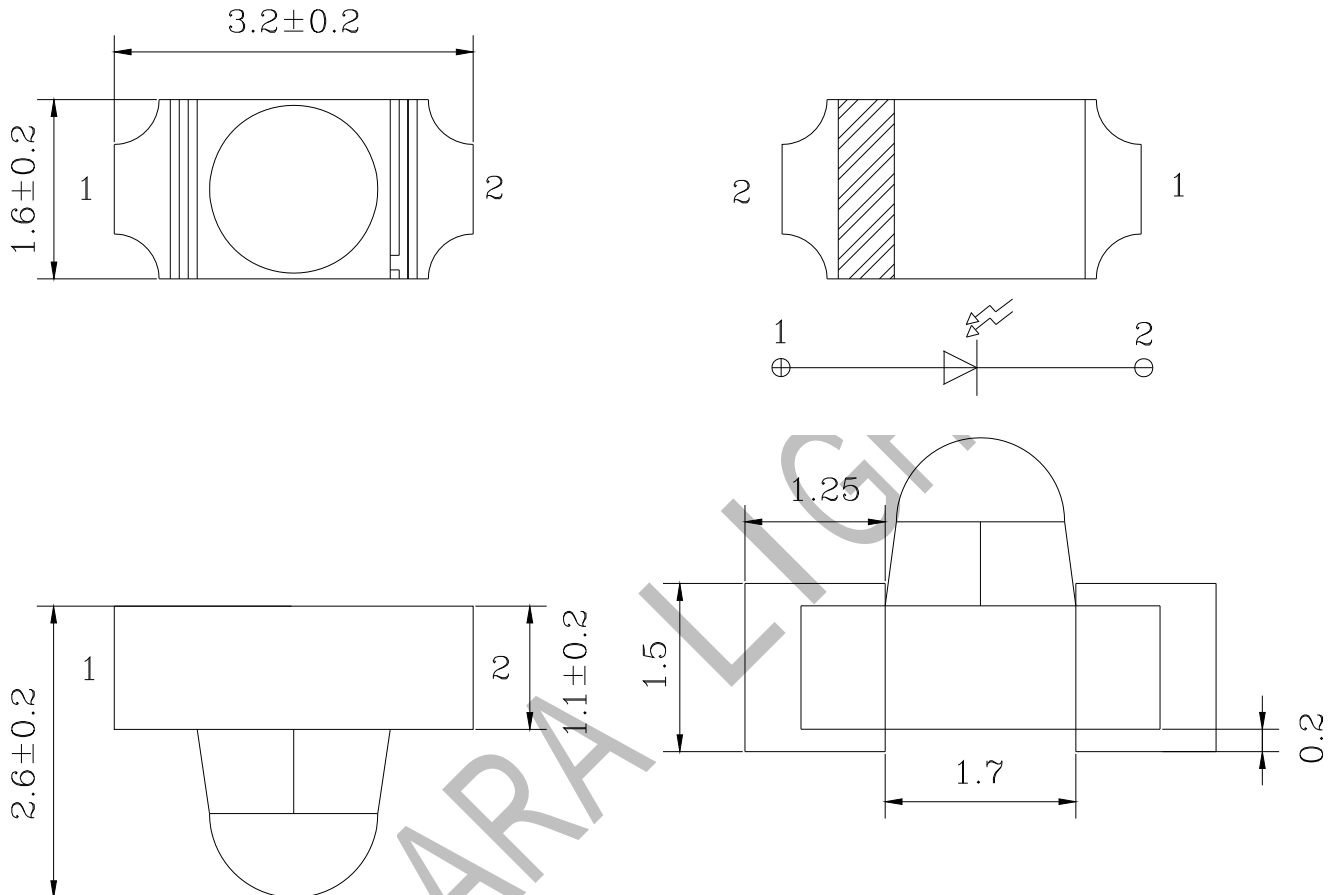

Notes:

1. All dimensions are in millimeters
2. Tolerances unless dimensions ± 0.1 mm
3. Suggested pad dimension is just for reference only. Please modify the pad dimension based on individual need.

FEATURES

- * 3.2*1.6*2.6 mm SMD LED
- * High photo sensitivity
- * Small junction capacitance
- * The product itself will remain within RoHS compliant version

CHIP MATERIALS

- * Dice Material : Silicon
- * Lens Color : Black

ABSOLUTE MAXIMUM RATING : (Ta = 25°C)

SYMBOL	PARAMETER	Rating	UNIT
Pd	Power Dissipation Per Chip	75	mW
VCEO	Collector-Emitter Voltage	30	V
VECO	Emitter-Collector-Voltage	5	V
IC	Collector Current	50	mA
Topr	Operating Temperature Range	-25°C ~+85°C	
Tstg	Storage Temperature Range	-40°C ~+85°C	
Tsol	Soldering Temperature*1	260°C	
tup	Pulse rise time	25us	
tdown	Pulse down time	25us	

 Notes: *1: Soldering time \leq 5 seconds

ELECTRO-OPTICAL CHARACTERISTICS : (Ta = 25°C)

Parameter	Symbol	Min.	Typ.	Max.	Unit	Test Condition
Collector-Emitter Breakdown Voltage	BVCE ○	30			V	IC=100 μ A Ee=0mW/cm2
Emitter-Collector Breakdown Voltage	BVEC ○	5			V	IE=100 μ A Ee=0mW/cm2
Collector-Emitter Saturation Voltage	VCE(sat)			0.4	V	IC=2mA Ee=1mW/cm2
Wavelength Of Peak Sensitivity	λ_p		940		nm	
Rang Of Spectral Bandwidth	λ	920		960	nm	10% of λ_P
Collector Dark Current	ICEO			30	nA	VCE=10V Ee=0mW/cm2
On State Collector Current	IC(ON)		1.0		mA	VCE=5V Ee=1mW /cm2
View Angle	2 θ 1/2		30		deg	VCE=10V Ee=0mW/cm2

Typical Electro-Optical Characteristics Curves
(25°C Ambient Temperature Unless Otherwise Noted)

Fig.1 Spectral Sensitivity

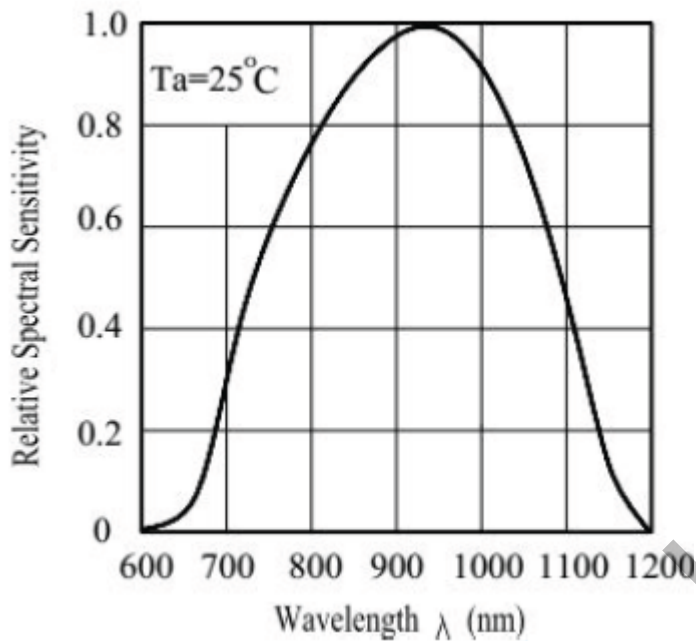

Fig.2 Collector Current vs. Irradiance

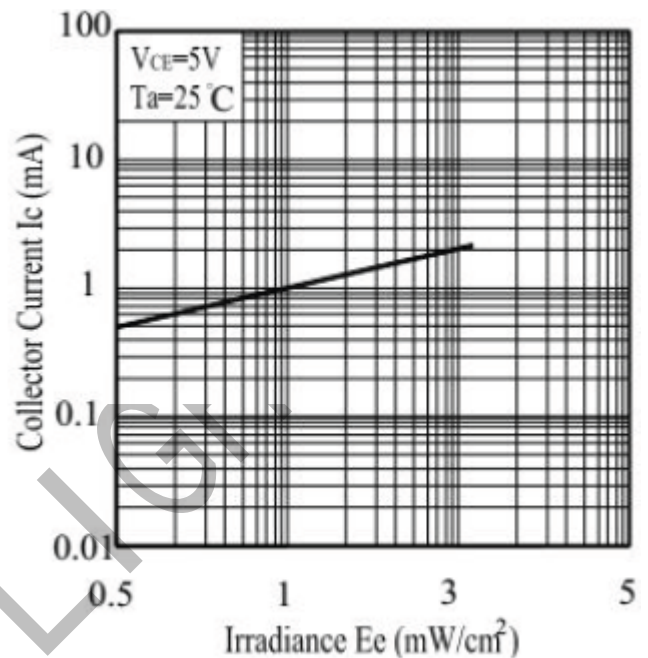

Fig.3 Collector Current vs. Collector-Emitter Voltage

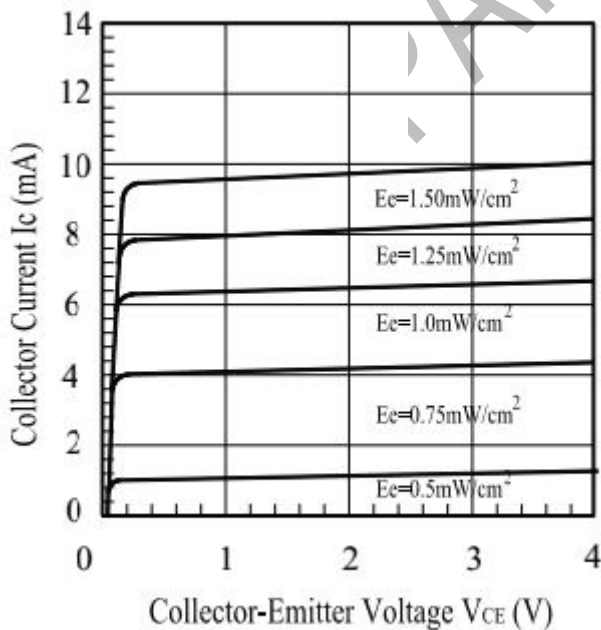
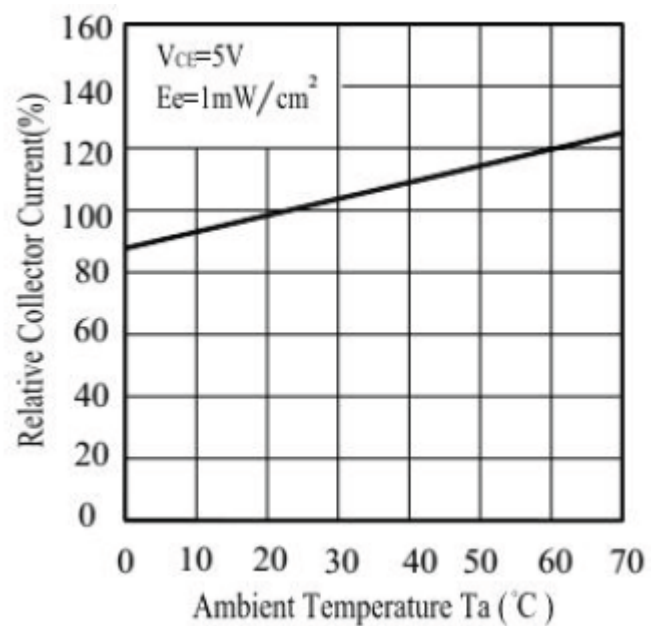

Fig.4 Relative Collector Current vs. Ambient temperature



Typical Electro-Optical Characteristics Curves
(25°C Ambient Temperature Unless Otherwise Noted)

Fig.5 Collector Dark Current vs. Ambient Temperature

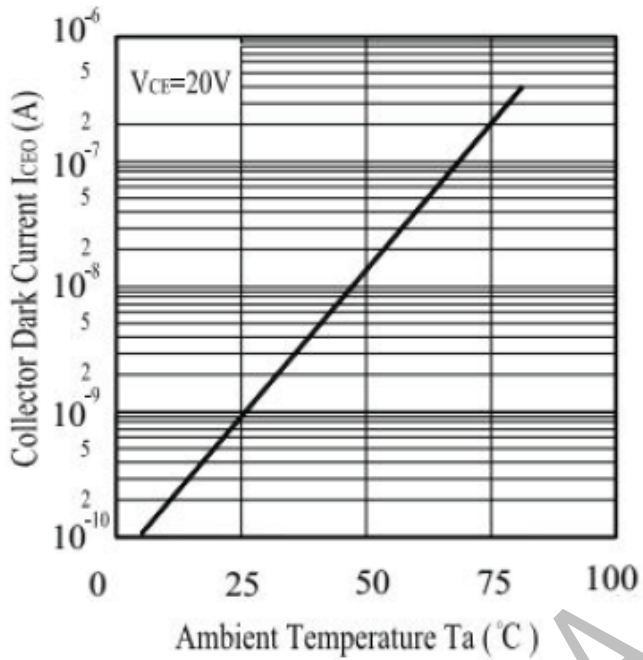
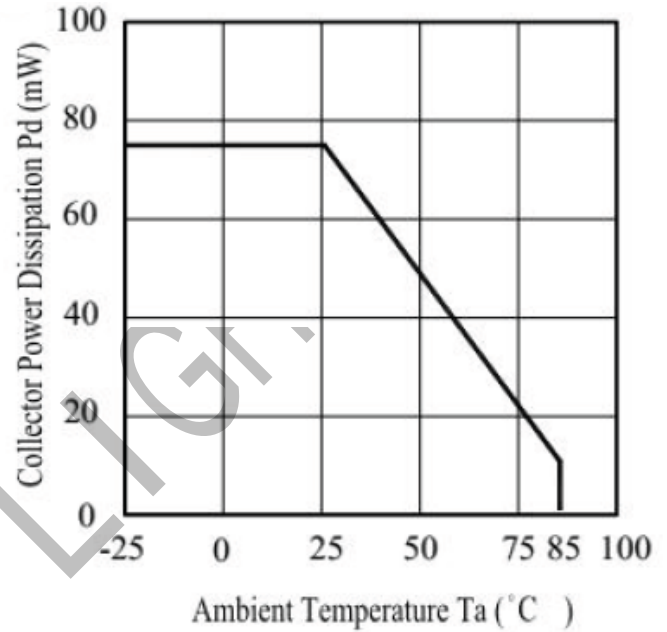
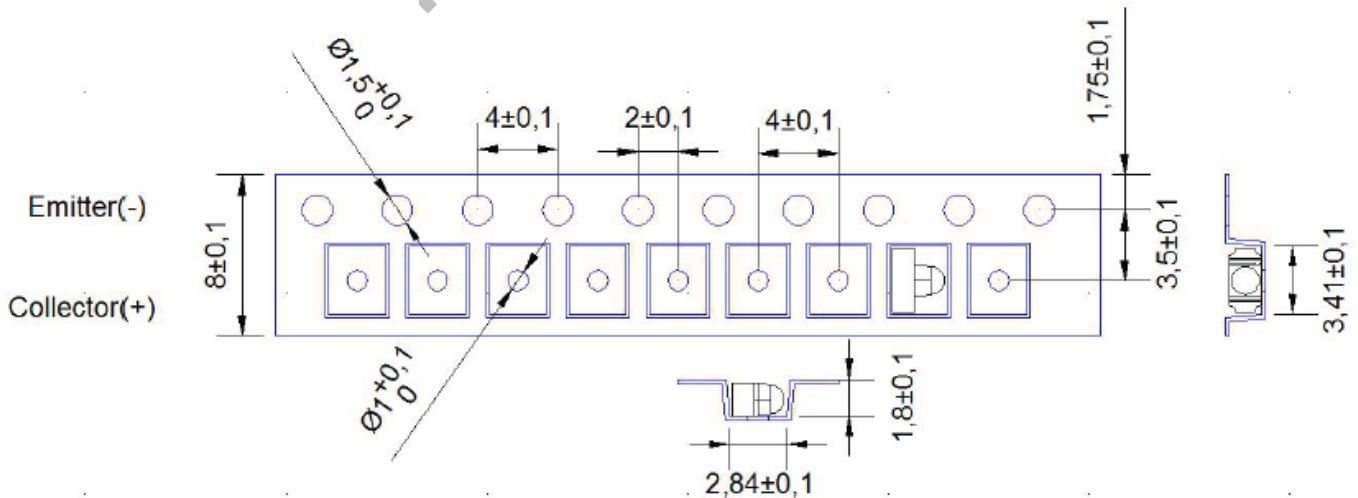

Fig.6 Collector Power Dissipation vs Ambient Temperature



Taping Specification: 2,000 pcs/Reel



Precautions For Use

1. Over-current-proof Customer must apply resistors for protection , otherwise slight voltage shift will cause current change (Burn out will happen).

2. Storage

2.1 Do not open moisture proof bag before the products are ready to use.

2.2 Before opening the package, the LEDs should be kept at 30°C or less and 90%RH or less

2.3 The LEDs should be used within a year.

2.4 After opening the package, the LEDs should be kept at 30°C or less and 60%RH or less

2.5 The LEDs should be used within 168 hours (7 days) after opening the package

2.6 If the moisture absorbent material (silica gel) has faded away or the LEDs have exceeded the storage time, baking treatment should be performed using the following conditions.

Baking treatment : 60±5°C for Min. 24 hours.

3. Soldering Condition

3.1 Pb-free solder temperature profile

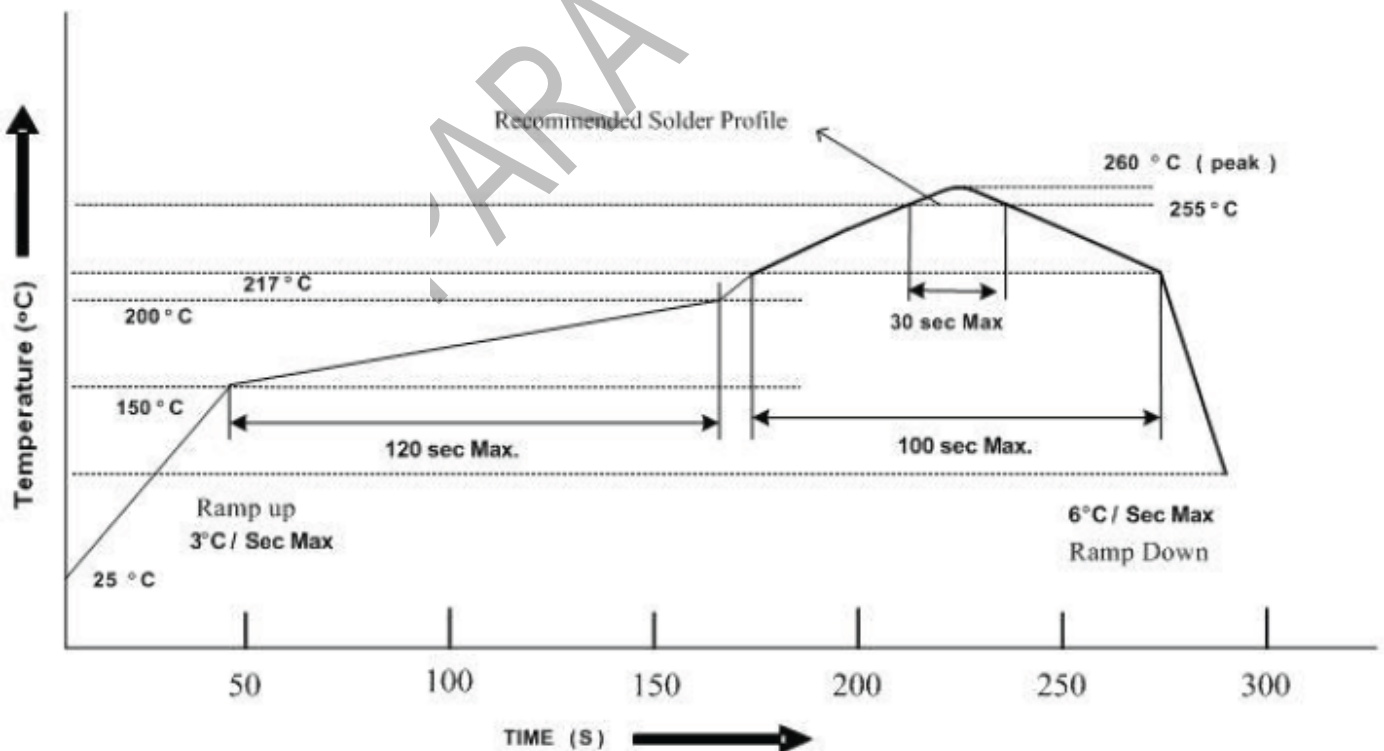

3.2 Reflow soldering should not be done more than two times.

3.3 When soldering, do not put stress on the LEDs during heating.

3.4 After soldering, do not warp the circuit board.

4. Soldering Iron

Each terminal is to go to the tip of soldering iron temperature less than 350°C for 3 seconds within once in less than the soldering iron capacity 25W. Leave two seconds and more intervals, and do soldering of each terminal. Be careful because the damage of the product is often started at the time of the hand solder.

5. Repairing

Repair should not be done after the LEDs have been soldered. When repairing is unavoidable, a double-head soldering iron should be used (as below figure). It should be confirmed beforehand whether the characteristics of the LEDs will or will not be damaged by repairing.

