



PARA LIGHT ELECTRONICS CO., LTD.

11F, No.8, Jiankang Rd,Zhonghe Dist,New Taipei City 253, Taiwan

Tel: 886-2-2225-3733

Fax: 886-2-2225-4800

E-mail: para@para.com.tw

<http://www.para.com.tw>

DATA SHEET

PART NO. : L-180PT1D1-BKR-TR10

REV : A / 2

CUSTOMER'S APPROVAL : _____

DCC : _____

DRAWING NO. : DS-52-20-003

DATE : 2020-12-09

Page : 1

● PACKAGE DIMENSIONS

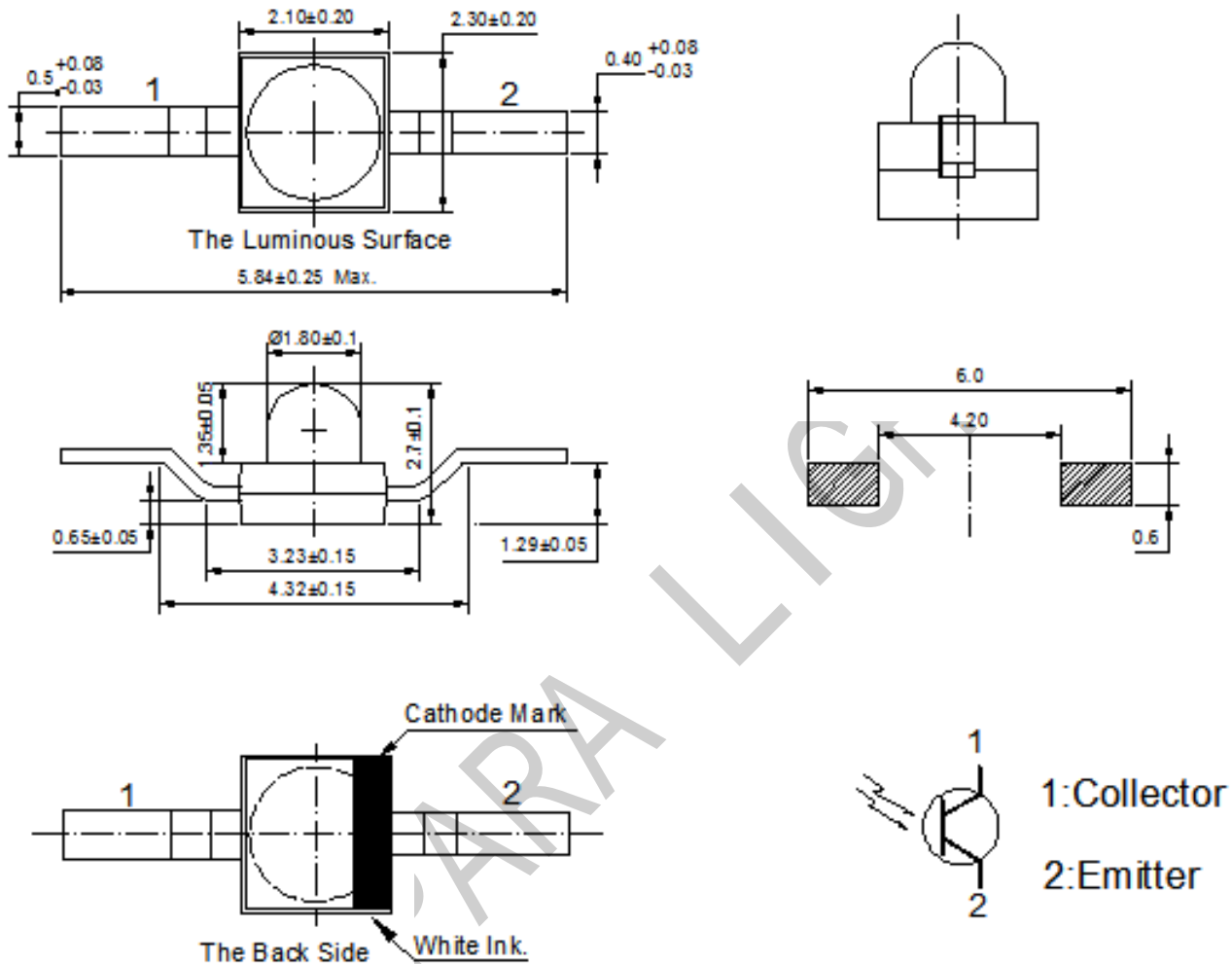

NOTES:

1. All dimensions are in millimeters (inches).
2. Tolerance is ± 0.254 mm (0.01") unless otherwise specified.
3. Lead spacing is measured where the leads emerge from the package.
4. Specifications are subject to change with notice.
5. The colors of the lines are specified in the specification unless otherwise specified.

● Features

- 2.1*2.3*2.7*Φ1.8 diameter and black package.
- Suitable for all SMT assembly and solder process.
- Available on tape and reel.
- Low power consumption.
- I.C.Compatible.
- Long life solid state reliability.
- Low operating voltage.
- RoHS compliant.



ATTENTION
 OBSERVE PRECAUTIONS
 FOR HANDLING
 ELECTROSTATIC
 DISCHARGE
 SENSITIVE
 DEVICES
 注意：操作时应注意静电
 敏感释放设备装置

● Applications

- Optical indicator
- Indoor display.
- Backlight for LCD,switch and symbol,display.
- General use.

● Selection Guide

Part No.	Dice	Lens Type	Viewing Angle
			2θ1/2
L-180PT1D1-BKR-TR10	Silicon Phototransistor(NPN)	Black Diffused	35°

● Absolute Maximum Ratings (Ta=25°C)

Parameter	Symbol	Rating	Unit
Collector-Emitter Voltage	V _{ceo}	30	V
Emitter-Collector Voltage	V _{eco}	5	V
Collector Current	I _c	20	mA
Collect Power Dissipation	P _c	75	mW
Operating Temperature Range	T _{opr}	-40°C ~ +85°C	
Storage Temperature Range	T _{stg}	-40°C ~ +100°C	
Soldering Condition	T _{sol}	Reflow(hand) soldering : 260°C(300°C)For 5 (3)Seconds	

● Electrical and optical characteristics($T_a=25^{\circ}\text{C}$)

Parameter	Symbol	Min.	Typ.	Max.	Unit	Test Condition
Collector-Emitter Breakdown Voltage	BV_{ceo}	30		100	V	$I_c=100\mu\text{A}$ $I_b=0$
Emitter-Collector Breakdown Voltage	BV_{eco}	5			V	$I_e=100\mu\text{A}$ $I_b=0$
Collector Dark Current	I_{ceo}			100	nA	$V_{ce}=20\text{V}$ $H=0\text{mW/cm}^2$
Collector-Emitter Saturation Voltage	$V_{ce(s)}$	---	---	0.4	V	$I_c=2\text{mA}$ $I_b=100\mu\text{A}$
Rise/Fall Time	T_r/T_f		15/15	---	μS	$V_{ce}=5\text{V}$ $I_c=1\text{mA}$ $R_I=1000\Omega$
Peak Collection Wavelength	λ_p		940		nm	
Current Gain	H_{fe}	200				$V_{ce}=5\text{V}$ $I_c=2\text{mA}$
Collector-base Capacitance	C_{CB}	5.4		7.4	PF	$F=1\text{MHZ}$ $V_{CB}=3\text{V}$
Spectral Range		730		1100	nm	

● Typical Electro-Optical Characteristics Curves

(25°C Ambient Temperature Unless Otherwise Noted)

Fig.1 Collector Power Dissipation vs. Ambient Temperature

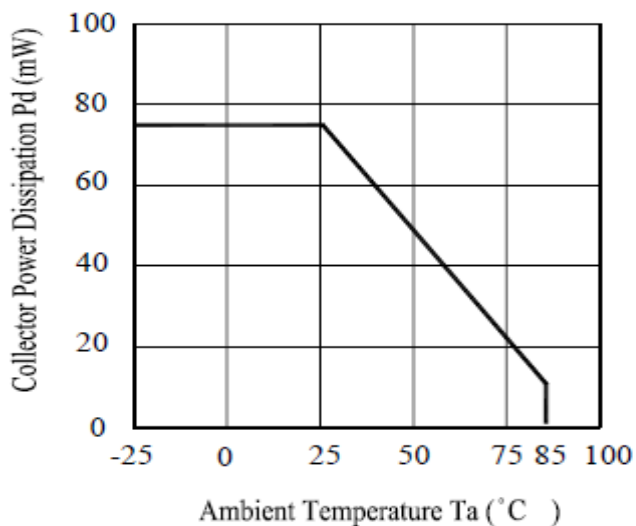
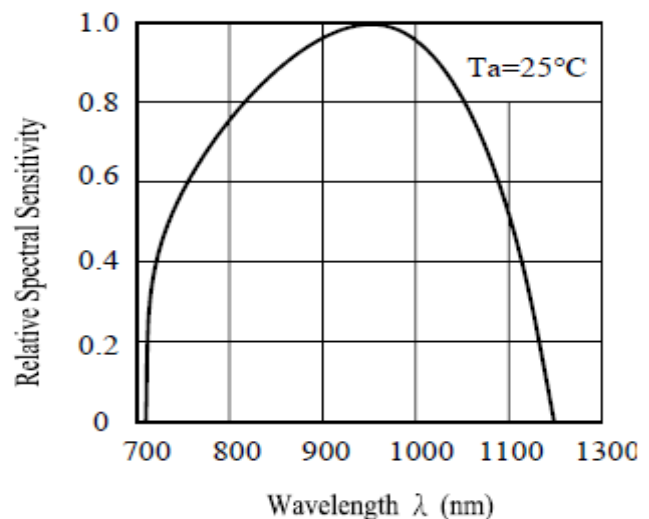

Fig.2 Spectral Sensitivity





1.8 mm AXIAL LED

L-180PT1D1-BKR-TR10

REV:A / 2

Fig.3 Relative Collector Current vs.
Ambient Temperature

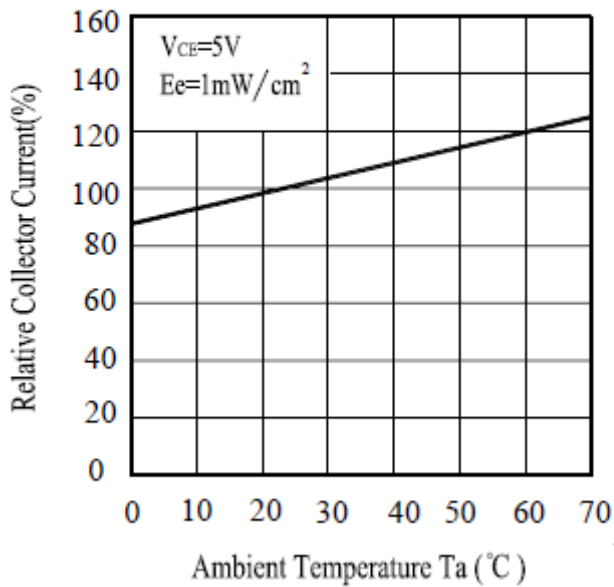

Fig.4 Collector Current vs.
Irradiance

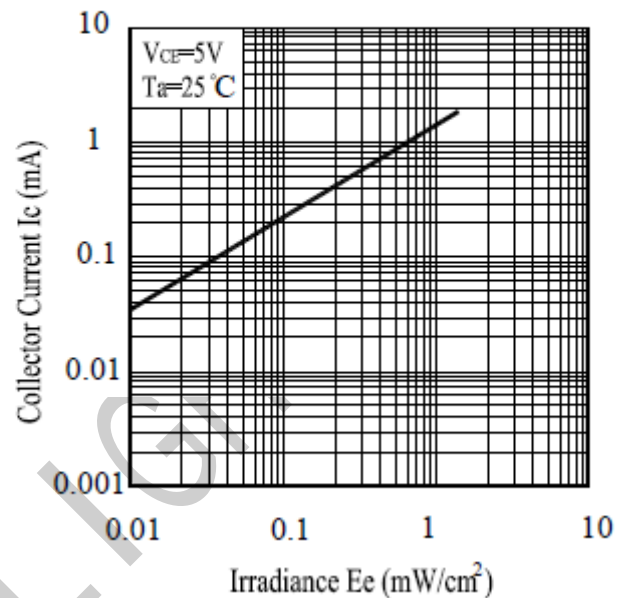

Fig.5 Collector Dark Current vs.
Ambient Temperature

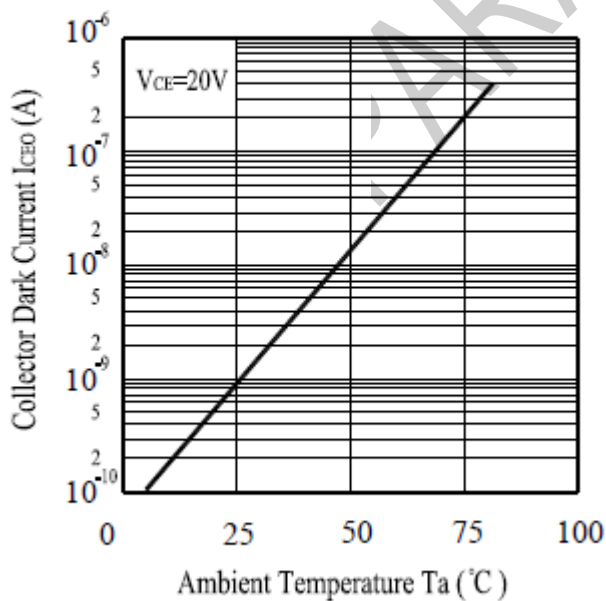
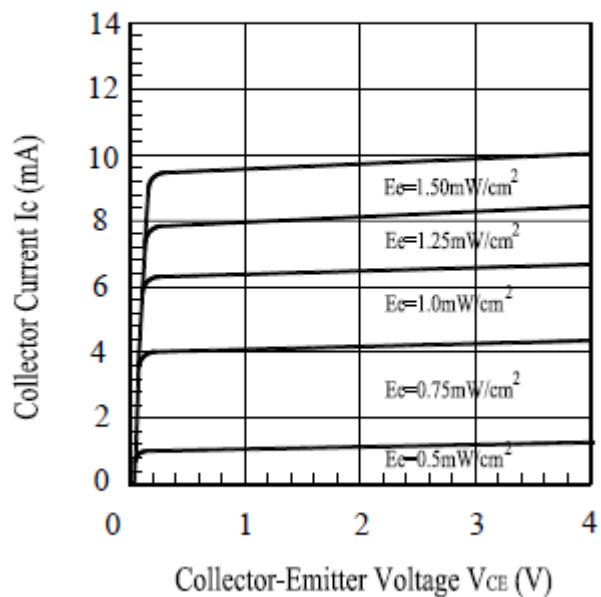

Fig.6 Collector Current vs.
Collector-Emitter Voltage





1.8 mm AXIAL LED

L-180PT1D1-BKR-TR10

REV:A / 2

● Reliability Test Items and Conditions

The reliability of products shall be satisfied with items listed below.

Confidence level : 90%.

LTPD : 10%.

Items	Test Condition	Test Hours/Cycles	Quantity	Ac/Re
Reflow Soldering	Temp. : 260°C±5°C Min. 5sec.	3times	22 PCS	0/1
Temperature Cycle	H : +85°C 30min.~ 5 min~ L : -40°C 30min.	300 Cycles	22PCS	0/1
Thermal Shock	H : +100°C 10min.~10 sec~ L : -40°C 10min.	100Cycles	22PCS	0/1
High Temperature Storage	Temp. : 100°C	1000Hrs	22PCS	0/1
Low Temperature Storage	Temp. : -40°C	1000Hrs	22PCS	0/1
Dc Life	IF =20mA	1000Hrs	22PCS	0/1
High Temperature / High Humidity	85°C/ 85%RH	500 rs	22PCS	0/1



1.8 mm AXIAL LED

L-180PT1D1-BKR-TR10

REV:A / 2

● Dimensions of Tape (Unit:mm)

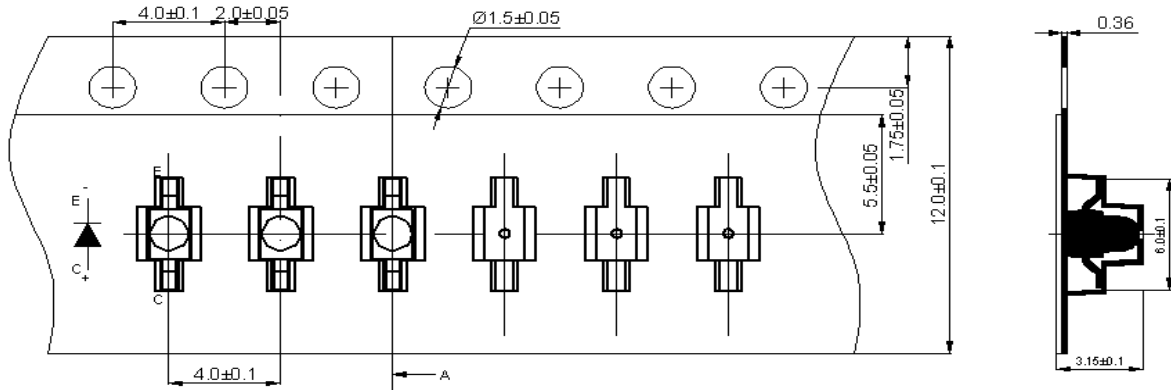

● Arrangement of Tape

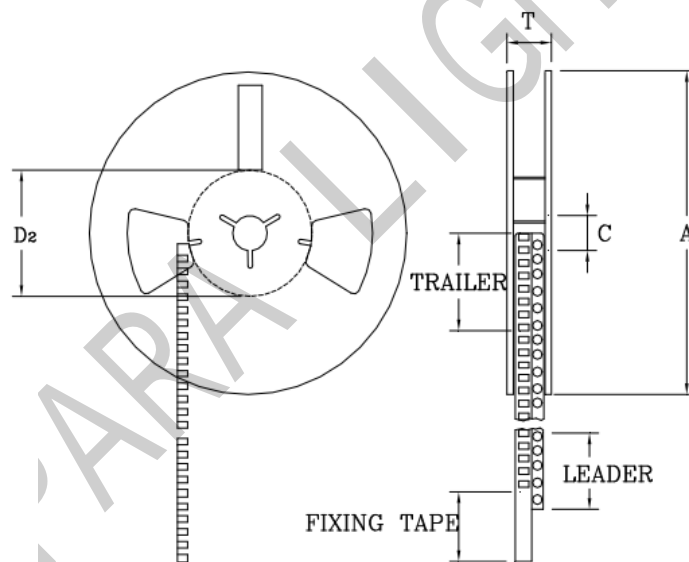

ITEM	Symbol	Specification			
		Min.		Max.	
		mm	inch	mm	inch
Flange Diameter	A	178	7.008	180	7.087
Hub Spindle Hole	C	12.5	0.492	13.5	0.531
Hub Diameter	D2	20.0	0.788	21.5	0.846
Flange Space Between Flanges	T	16.0	0.629	17.0	0.669

Notes:

1. Empty component pockets are sealed with top cover tape;
2. The maximum number of missing lamps is two;
3. The cathode is oriented towards the tape sprocket hole;
4. 1000 pcs/Reel.

● Reflow Soldering Instructions

<Pb-free solder>

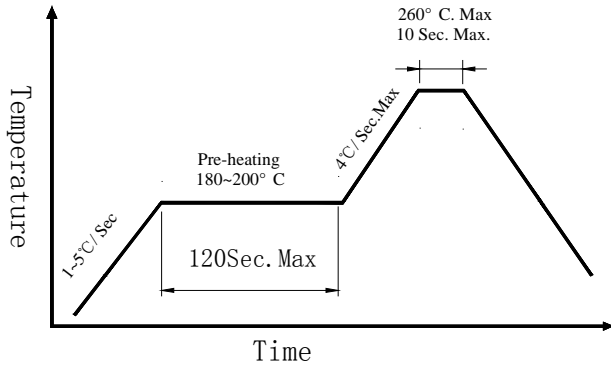

<Lead solder>

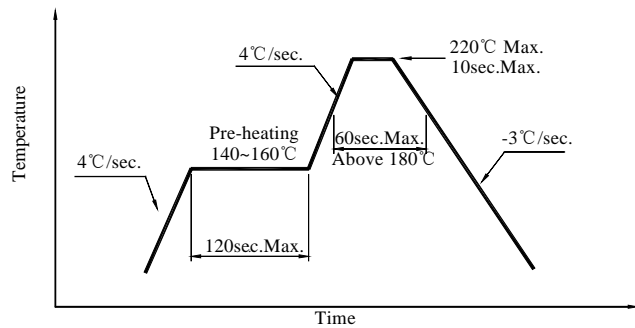

- 1.Reflow soldering should not be done more than two times
- 2.When soldering,do not put stress on the LEDs during heating

● Soldering Iron

- 1.When hand soldering,keep the temperature of iron below less 300°C less than 3 seconds.
- 2.The hand solder should be done only one time.
- 3.During soldering,take care not to press the trip of iron against the lead.
- 4.To prevent heat from being transferred directly to the lead,hold the lead with a pair of tweezers while soldering.

● DIP Soldering(Wave Soldering)

- Preheating:120°C~150°C ,within 120~180 sec.
 Operation heating:245°C ±5°C within 5 sec. ;260°C (Max.)
 Gradual Cooling(Avoid quenching).

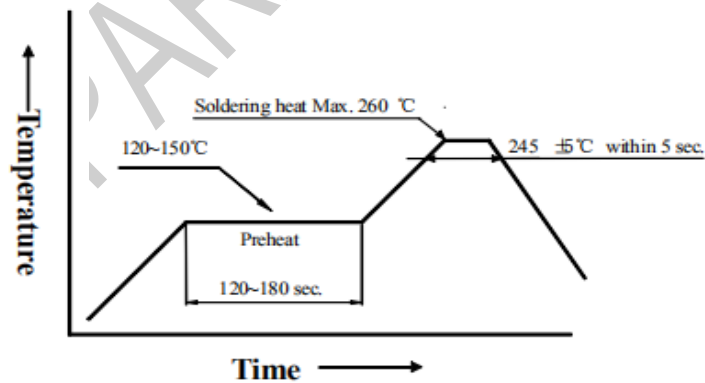

● Cautions

Application

Care must be taken to provide the current limiting resistor in the circuit so as to drive the BEKINRY LEDs within the rated figures.Also,caution should be taken not to overload BEKINRY LEDs with instantaneous voltage at the turning ON and OFF of the circuit. When using the pulse drive care must be taken to keep the average current within the rated figures.Also,the circuit should be designed so as be subjected to reverse voltage when turning off the BEKINRY LEDs.



1.8 mm AXIAL LED

L-180PT1D1-BKR-TR10

REV:A / 2

Storage

1. Before opening original package, it is recommended to store them in the following environment: Temperature: 5°C~30°C / Humidity: 60%RH max.
2. After opening original package, the storage ambient for the LEDs should be in 5~30°C temperature and 60% or less relative humidity.
3. In order to avoid moisture absorption, it is recommended that the LEDs that out of the original package should be stored in a sealed container with appropriate desiccant, or in desiccators with nitrogen ambient.
4. The LEDs should be used within 168hrs (7 days) after opening the package. Once been mounted, soldering should be quick.
5. If the moisture absorbent material (silica gel) has faded away or the LEDs stored out of original package for more than 168hrs (7 days), baking treatment should be performed using the conditions: 60°C at least 24 hours.

ESD (Electrostatic Discharge)-Protection

A LED (especially the Blue 、 White and Green product) is an ESD sensitive component, and static electricity or power surge will damage the LED. ESD-damaged LEDs will exhibit abnormal characteristics such as high reverse leakage current, low forward voltage, or “no light-up” at low currents, etc.

Some advice as below should be noticed:

1. A conductive wrist strap or anti-electrostatic glove should be worn when handling these LEDs.
2. All devices, equipment, machinery, work tables and storage racks, etc. must be properly grounded.
3. Use anti-static package or boxes to carry and storage LEDs. And ordinary plastic package or boxes is forbidden to use.
4. Use ionizer to neutralize the static charge during handling or operating.
5. All surfaces and objects within 1 ft close to LEDs measure less than 100V.

Cleaning

Use alcohol-based cleaning solvents such as IPA (isopropyl alcohol) to clean LEDs if necessary.

Others

1. The LEDs described here are intended to be used for ordinary electronic equipment (such as office equipment, communication equipment and household applications). Consult Gtlight's Sales in advance for the applications in which exceptional reliability is required, particularly when the failure or malfunction of the LEDs may directly jeopardize life or health. (such as in aviation, transportation, traffic control equipment, medical and life support systems and safety devices)



1.8 mm AXIAL LED

L-180PT1D1-BKR-TR10

REV:A / 2

2. The light output from the high luminous intensity LEDs may cause injury to human eyes when viewed directly.
3. The appearance and specifications of the product may be modified for improvement without prior notice.

PARA LIGHT