



# PARA LIGHT ELECTRONICS CO., LTD.

11F., No. 8, Jiankang Rd., Zhonghe Dist., New Taipei City 235, Taiwan,

Tel: 886-2-2225-3733

Fax: 886-2-2225-4800

E-mail: [para@para.com.tw](mailto:para@para.com.tw)

<http://www.para.com.tw>

## DATA SHEET

PART NO.:L-S115JFWDT-LCFC

REV: A / 3

CUSTOMER'S APPROVAL : \_\_\_\_\_

DCC : \_\_\_\_\_

DRAWING NO. :DS-78-16-006

DATE : 2024-04-15

Page 1 of 14

LD-R/E020

● PACKAGE OUTLINE DIMENSIONS

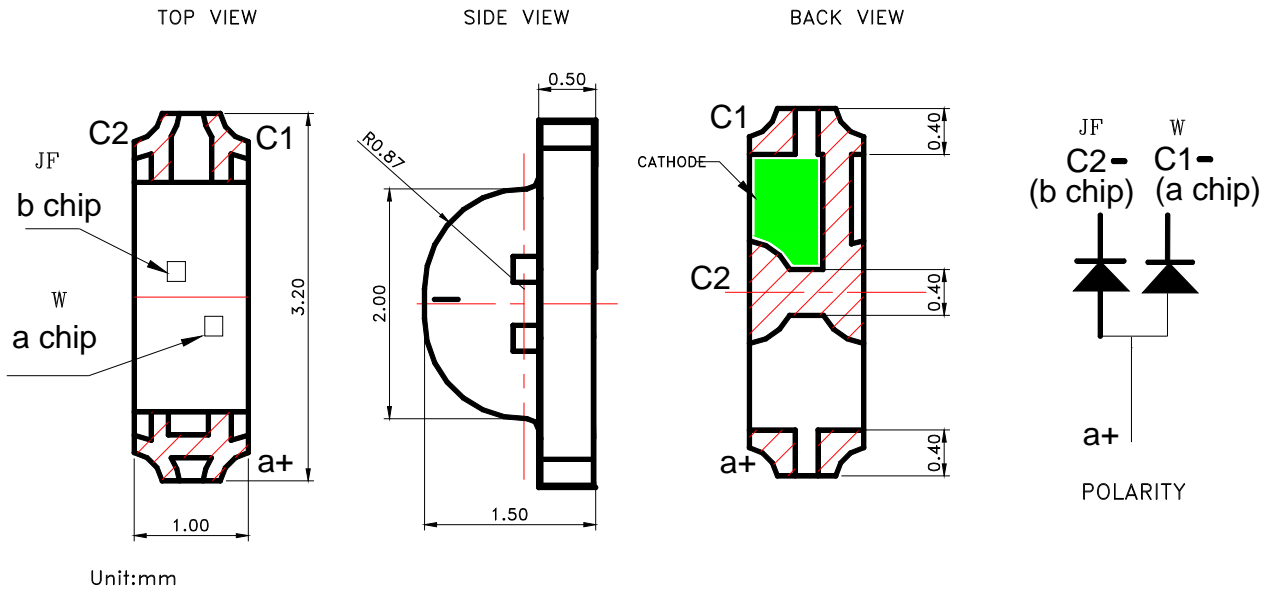

Notes:

1. a chip : White; b chip: Super Amber
2. All dimensions are in millimeters.
3. Tolerance is  $\pm 0.1\text{mm}$  (.004") unless otherwise noted.

● Features

- \* Dual color, common anode, side view Chip LED.
- \* Package in 8mm tape on 7" diameter reels.
- \* Compatible with automatic Pick & Place equipment.
- \* Compatible with Reflow soldering and Wave soldering processes.
- \* EIA STD package.
- \* I.C. compatible.
- \* Pb free product.
- \* Meet RoHS Green Product.
- \* Moisture sensitivity level: 3

● **Chip Materials**

chip	Light Color	Dice Material	Lens Color
a	W: White	InGaN	Yellow Diffused.
b	JF: Super Amber.	AlInGaP	

● **Absolute Maximum Ratings(Ta=25°C)**

Symbol	Parameter	Rating		Unit
		Super Amber	White	
PD	Power Dissipation	60	60	mW
IPF	Peak Forward Current (1/10 Duty Cycle, 0.1ms Pulse Width)	30	60	mA
IF	Continuous Forward Current	25	20	mA
VR	Reverse Voltage	5	5	V
ESD	Electrostatic Discharge Threshold(HBM) <sup>Note A</sup>	/	1000	V
Topr	Operating Temperature Range	-40 ~ +85		°C
Tstg	Storage Temperature Range	-40 ~ +85		°C

Note A:

HBM: Human Body Model. Seller gives no other assurances regarding the ability of to withstand ESD

● **Electro-Optical Characteristics(Ta=25°C)**

Parameter	Symbol	Super Amber	Unit	Test Condition
Luminous Intensity	Min.	11.2	mcd	IF=5mA
	Typ.	18		
Viewing Angle	Typ.	2θ 1/2	deg	Note 2
Dominant Wavelength	Typ.	λ d	nm	IF=5mA
Spectral Line Half-Width	Typ.	Δ λ	nm	
Forward Voltage	Typ.	2.0	V	IF =5mA
	Max.	2.4		
Reverse Current	Max.	IR	μ A	VR = 5V



# SURFACE MOUNT DEVICE LED

Part No. :L-S115JFWDT-LCFC

REV:A / 3

White Parameter	Symbol	Min.	Typ.	Max.	Unit	Test Condition
Luminous Intensity	IV	45	71.5	180	mcd	IF=5mA
Viewing Angle	2θ 1/2		130		Deg	Note 2
CIE Chromaticity	X		0.270			IF=5mA
CIE Chromaticity	Y		0.255			
Forward Voltage	VF	2.6	2.8	3.1	V	IF = 5mA
Reverse Current	IR			50	μ A	VR = 5V

## Bin Code List

Luminous Intensity(IV), Unit:mcd@5mA					
White (a chip)			Super Amber(b chip)		
Bin Code	Min	Max	Bin Code	Min	Max
P	45	71	L	11.2	18
Q	71	112	M	18	28
R	112	180	N	28	45

Tolerance of each bin are ± 15%

Forward Voltage(VF), Unit:V@5mA White			Dominant Wavelength (Hue), Unit:nm @5mA Super Amber		
Bin Code	Min	Max	Bin Code	Min	Max
11	2.6	2.7	OA	600	605
12	2.7	2.8	OB	605	610
13	2.8	2.9			
14	2.9	3.0			
15	3.0	3.1			

Tolerance of each bin are ± 0.1 Volt

Tolerance of each bin are ± 1nm

Color Rank (CIE chromaticity X , Y) @ 5mA									
Rank B1					Rank B2				
X	0.234	0.234	0.254	0.254	X	0.234	0.234	0.254	0.254
Y	0.17	0.202	0.23	0.198	Y	0.202	0.235	0.263	0.23
Rank B3					Rank B4				
X	0.254	0.254	0.274	0.274	X	0.254	0.254	0.274	0.274
Y	0.23	0.198	0.226	0.258	Y	0.23	0.263	0.291	0.258
Rank S1					Rank S2				
X	0.274	0.274	0.294	0.294	X	0.274	0.274	0.294	0.294
Y	0.226	0.258	0.286	0.254	Y	0.258	0.291	0.319	0.286

\* Measurement of Color coordinates : +/- 0.02

L-S115JFWDT-LCFC白光案

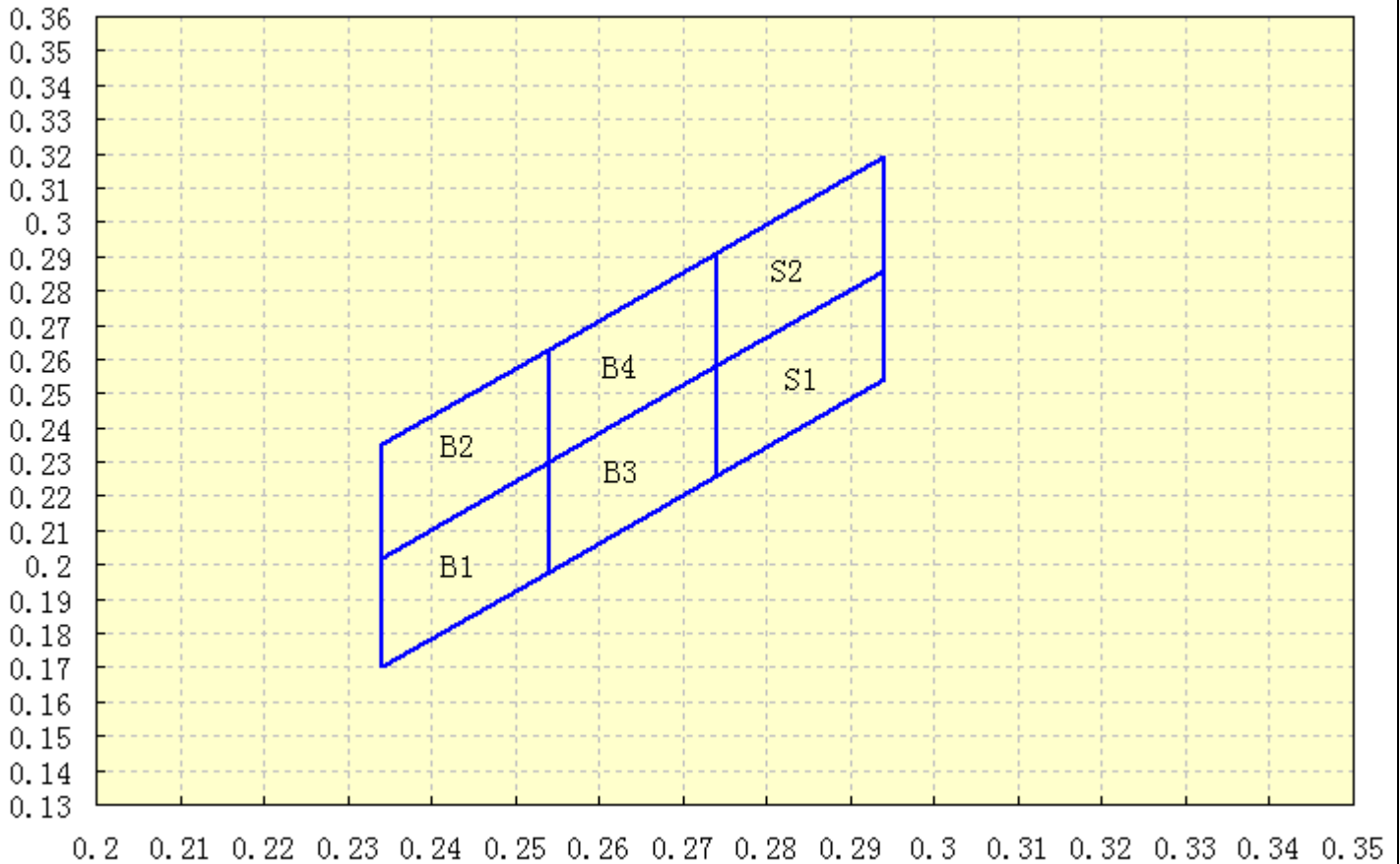

Notes:

1. Luminous intensity is measured with a light sensor and filter combination that proximates the CIE eye-response curve.
2.  $\theta_{1/2}$  is the off-axis angle at which the luminous intensity is half the axial luminous intensity.
3. Caution in ESD :  
Static Electricity and surge damages the LED. It is recommended use a wrist band or anti-electrostatic glove when handling the LED. All devices, equipment and machinery must be properly grounded.
4. Major standard testing equipment by “Instrument System” Model : CAS140B Compact Array Spectrometer and “KEITHLEY” Source Meter Model : 2400.

### ● White Typical Electro-Optical Characteristics Curves

(25°C Ambient Temperature Unless Otherwise Noted)

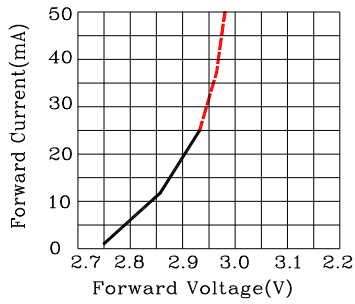

Fig.2 Forward Current vs.Forward Voltage

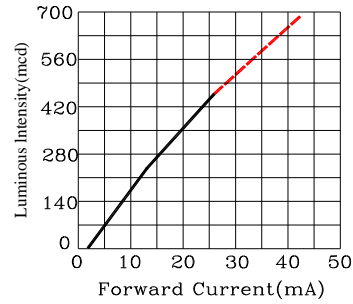

Fig.3 Luminous Intensity vs.Forward Current

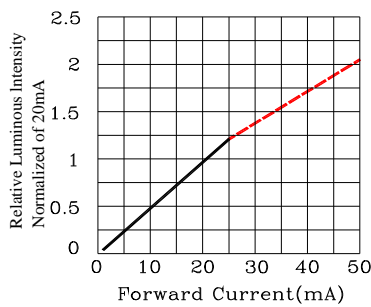

Fig.4 Relative Luminous Intensity vs.Forward Current

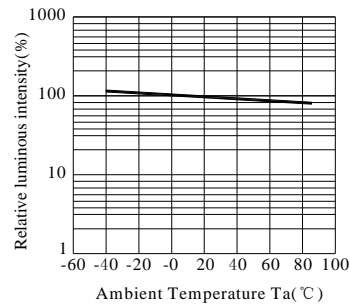

Fig.5 Luminous Intensity vs.Ambient Temperature

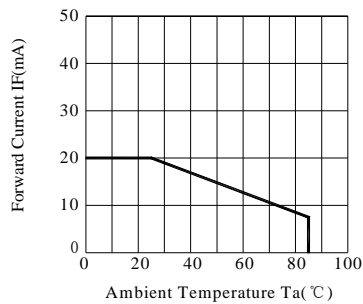

Fig.6 Forward Current Derating Curve

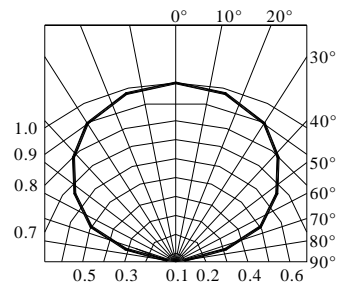

Fig.7 Relative Intensity vs.Angle

### ● Super Amber Typical Electro-Optical Characteristics Curves

(25°C Ambient Temperature Unless Otherwise Noted)

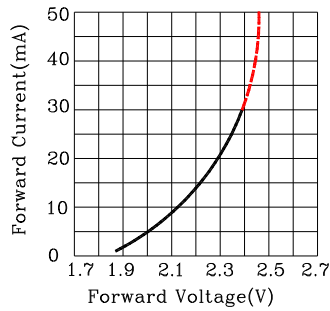

Fig.2 Forward Current vs.Forward Voltage

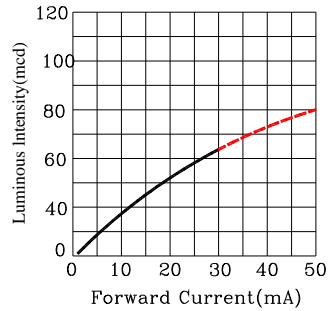

Fig.3 Luminous Intensity vs.Forward Current

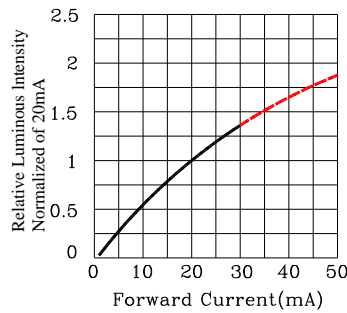

Fig.4 Relative Luminous Intensity vs.Forward Current

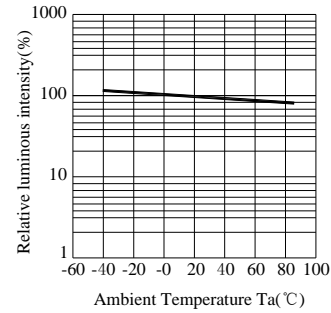

Fig.5 Luminous Intensity vs.Ambient Temperature

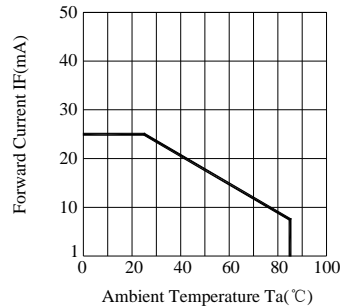

Fig.6 Forward Current Derating Curve

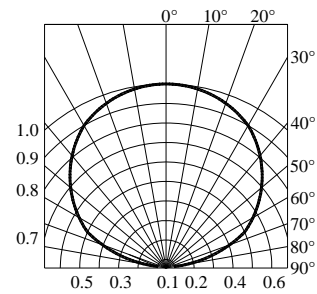

Fig.7 Relative Intensity vs.Angle

● Label Explanation



ITEM CODE:PARA LIGHT

PART NO: L-S115JFWDT-LCFC

IV --- Luminous Intensity Code

LOT NO: EN S L 12 09 0110  
          A    B    C    D    E    F

A---EN: Emos Code

B---S:SMD

L---Local

D---Year

E---Month

F---SPEC.

PACKING QUANTITY OF BAG :

3000pcs for 150、170、110、155、115 series

4000pcs for 191 series

5000pcs for 192 series

DATE CODE: 2012 09 10  
                  G    H    I

G--- Year

H--- Month

I --- Day

● Typical Electro-Optical Characteristics Curves

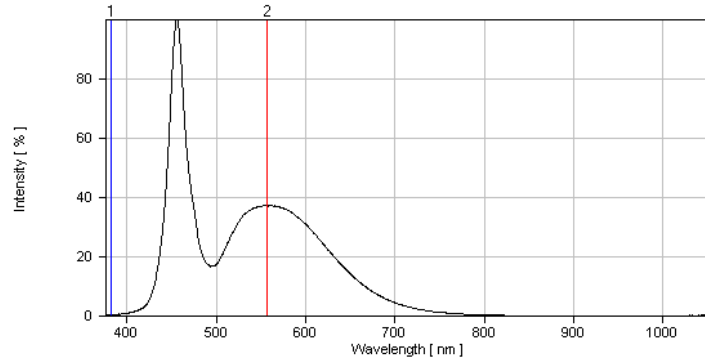

Fig.2 White Relative Intensity vs. Wavelength

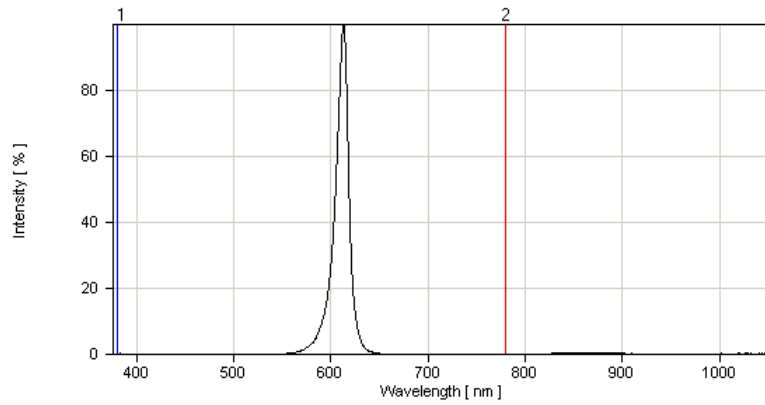
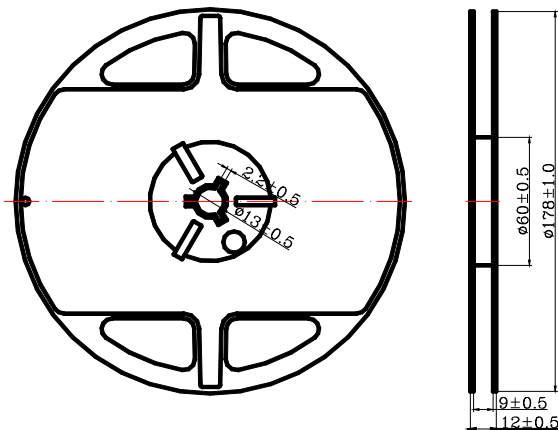

Fig.2 Bright Amber Relative Intensity vs. Wavelength

● Reel Dimensions



Notes:

1. Taping Quantity: 3000pcs.
2. The tolerances unless mentioned is  $\pm 0.1\text{mm}$ , Angle  $\pm 0.5^\circ$  , Unit: mm.

● Package Dimensions Of Tape And Reel

Progressive direction

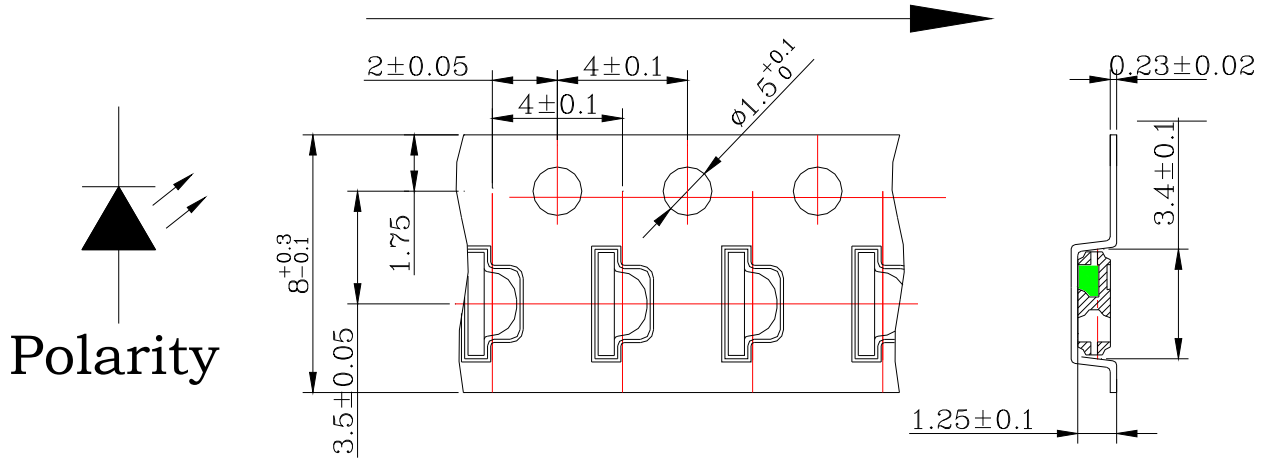

Notes : All dimensions are in millimeters.

**● Cleaning**

- \* If cleaning is required , use the following solutions for less than 1 minute and less than 40°C.
- \* Appropriate chemicals: Ethyl alcohol and isopropyl alcohol.
- \* Effect of ultrasonic cleaning on the LED resin body differs depending on such factors as the oscillator output, size of PCB and LED mounting method. The use of ultrasonic cleaning should be enforced at proper output after confirming there is no problem.

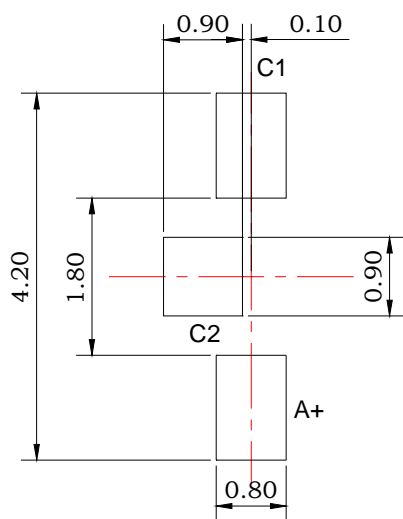
**● Suggest Soldering Pad Dimensions**

Direction of PWB camber  
and go to reflow furnace

● Suggest Sn/Pb IR Reflow Soldering Profile Condition:

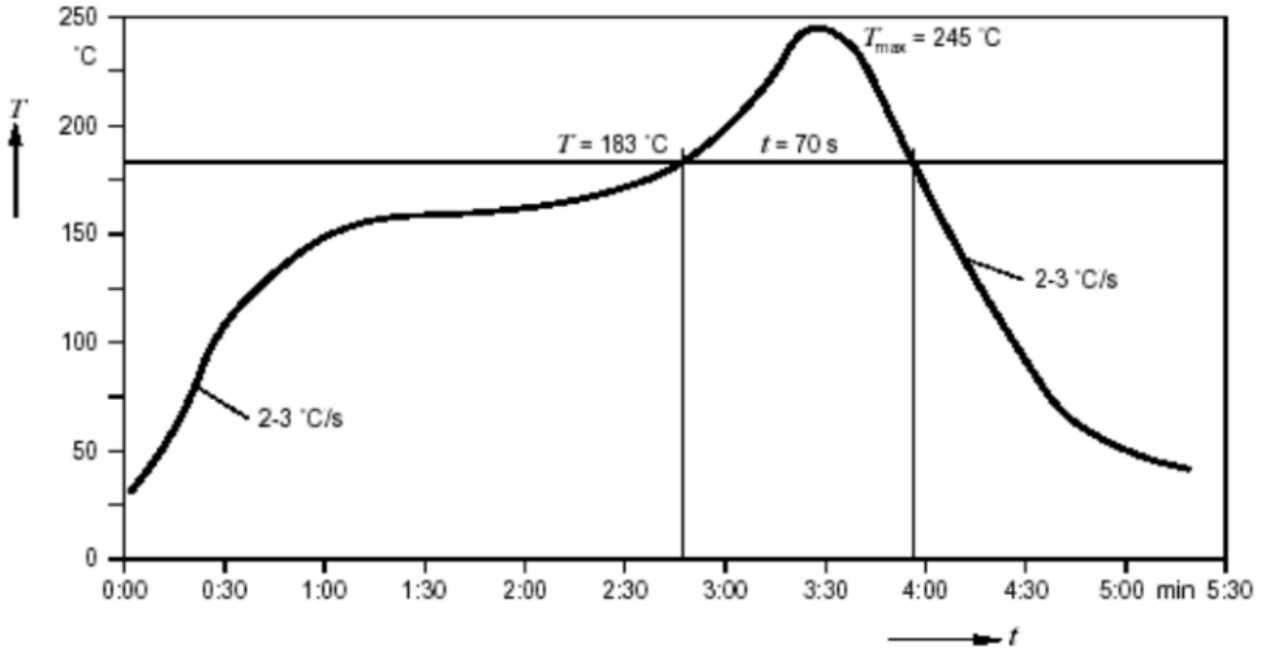

● Suggest Pb-Free IR Reflow Soldering Profile Condition:

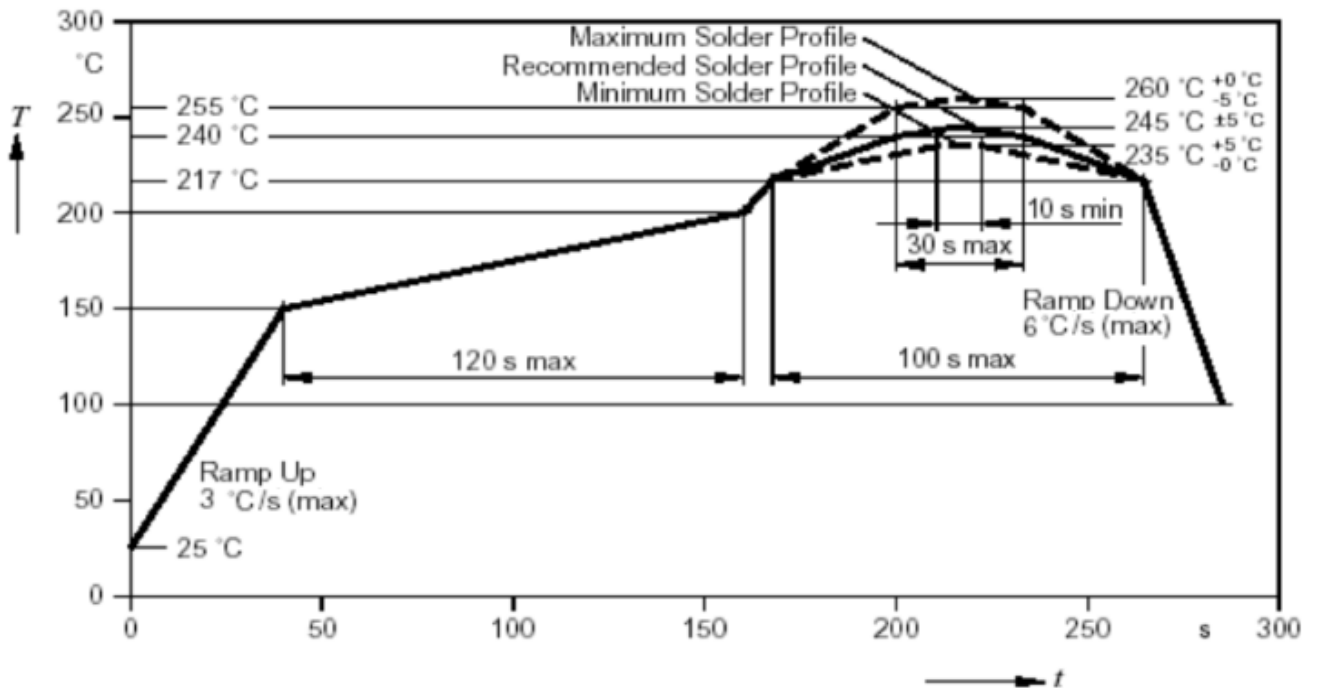

## ● CAUTIONS

### 1.Application Limitation :

The LED's described here are intended to be used for ordinary electronic equipment (such as office equipment, communication equipment and household application).Consult PARA's sales in advance for information on application in which exceptional quality and reliability are required, particularly when the failure or malfunction of the LED's may directly jeopardize life or health (such as airplanes, automobiles, traffic control equipment, life support system and safety devices).

### 2.Storage :

Do not open moisture proof bag before the products are ready to use.

Before opening the package: The LEDs should be kept at 30°C or less and 90%RH or less.

If the moisture absorbent material (silica gel) has faded away or the LEDs have exceeded the storage time, baking treatment should be performed using the following conditions.

Baking treatment: 60±5°C for 24 hours.

### 3.Soldering(Standard Process) :

Do not apply any stress to the lead frame during soldering while the LED is at high temperature.

Recommended soldering condition.

Reflow Soldering :

Pre-heat 120~150°C, 120sec. MAX., Peak temperature : 240°C Max. Soldering time : 10 sec Max.

Soldering Iron : (Not recommended)

Temperature 300°C Max., Soldering time : 3 sec. Max.(one time only), power dissipation of iron : 20W Max. use SN60 solder of solder with silver content and don't to touch LED lens when soldering.

Wave soldering :

Pre-heat 100°C Max, Pre-heat time 60s Max, Solder wave 260°C Max, Soldering time 5 sec. Max. preformed consecutively cooling process is required between 1st and 2nd soldering processes.

4. Lead-Free Soldering

For Reflow Soldering :

- 1、 Pre-Heat Temp : 150-180°C,120sec.Max.
- 2、 Soldering Temp : Temperature Of Soldering Pot Over 230°C,40sec.Max.
- 3、 Peak Temperature : 260°C , 5sec.
- 4、 Reflow Repetition : 2 Times Max.
- 5、 Suggest Solder Paste Formula 93.3 Sn/3.1 Ag/3.1 Bi /0.5 Cu

For Soldering Iron (Not Recommended) :

- 1、 Iron Tip Temp : 350°C Max.
- 2、 Soldering Iron : 30w Max.
- 3、 Soldering Time : 3 Sec. Max. One Time.

For Dip Soldering :

- 1、 Pre-Heat Temp : 150°C Max. 120 Sec. Max.
- 2、 Bath Temp : 265°C Max.
- 3、 Dip Time : 5 Sec. Max.

5. Drive Method

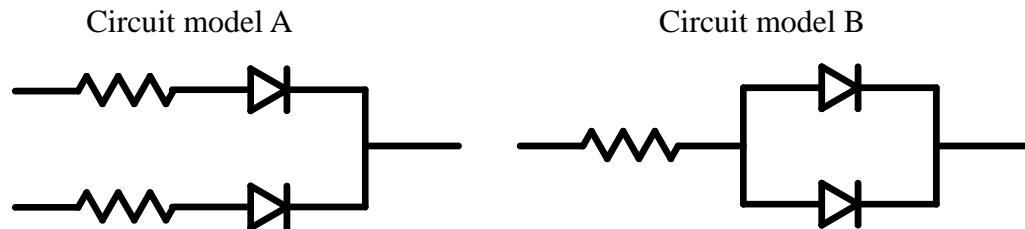

(A)Recommended circuit.

(B)The difference of brightness between LED`s could be found due to the Vf-If characteristics of LED.