



**PARA LIGHT ELECTRONICS CO., LTD.**

11F., No. 8, Jiankang Rd., Zhonghe Dist., New Taipei City 235, Taiwan

Tel: 886-2-2225-3733

Fax: 886-2-2225-4800

E-mail: [para@para.com.tw](mailto:para@para.com.tw)

[http:// www.paralighttaiwan.com](http://www.paralighttaiwan.com)

**DATA SHEET**

**PART NO.: LT3535IR4CT-N-Y-E-B**

**REV: A/1**

CUSTOMER'S APPROVAL : \_\_\_\_\_

DCC : \_\_\_\_\_

DRAWING NO. : DS-7A-19-0006

DATE :2020-04-10

PAGE

1 of 10

● **Features**

- \* Top view, Wide view angle,
- \* EIA STD package,
- \* Compatible with automatic Pick & Place equipment.
- \* Compatible with IR Reflow soldering and TTW soldering.
- \* Pb free product and acceptable lead-free process.
- \* Meet RoHS Green Product.

● **Package Outline Dimensions**

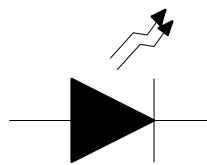
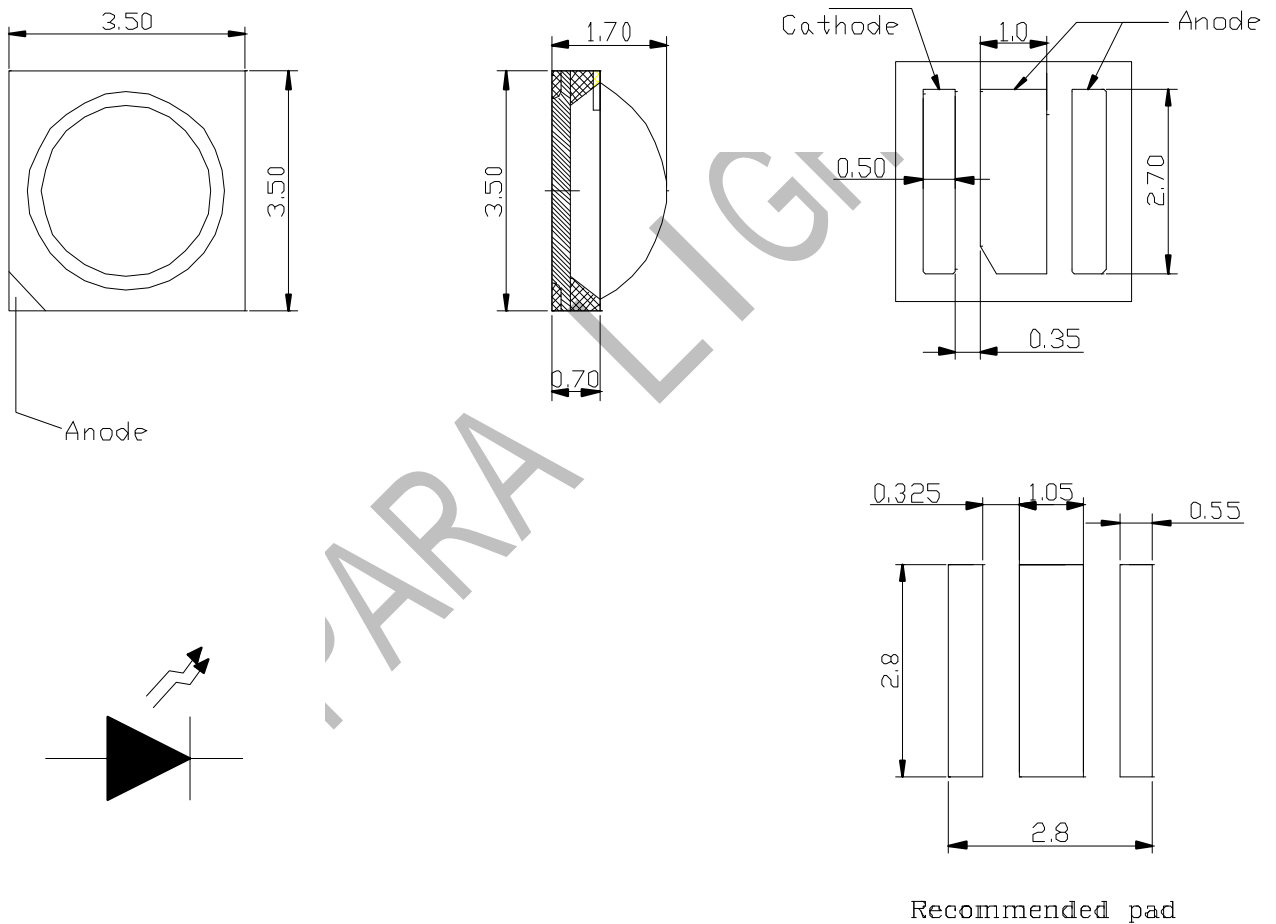

Notes:

1. All dimensions are in millimeters.
2. Tolerance is  $\pm 0.15\text{mm}$  (.004") unless otherwise noted.

● **CHIP MATERIALS**

- \* Dice Material : AlGaAs/GaAs
- \* Lens Color : Water Clear

● **Absolute Maximum Ratings(Ta=25°C)**

Parameter	symbol	Rating	Unit
Forward Current	IF	≤1000	mA
Reverse Voltage	VR	5	V
Operating Temperature	Topr	-40~ +85	°C
Storage Temperature	Tstg	-40 ~ +100	°C
Junction Temperature	Tj	125	°C
IR Reflow Soldering	Tsol	260°C max 5s /2time	

● **Electro-Optical Characteristics (Ta=25°C)**

Product model	Parameter	Symbol	Condition	Min	Typ	Max.	Unit
LT3535IR4CT-N-Y-E-B	Reverse Current	IR	VR=5V			10	μA
	Forward Voltage	VF	IF=350mA	1.6		2.6	V
			IF=1A	1.8		2.8	V
	Radiant Intensity	le	IF=350mA		60		mW/sr
	Total Radiant Flux	Φe	IF=350mA	165	240	300	mW
	Radiant Intensity	le	IF=1A		120		mW /sr
	Total Radiant Flux	Φe	IF=1A		600		mW
	Peak wavelength	λp	IF=350mA	840	850	870	nm
Half Intensity Angle	2θ1/2	IF=350mA		150		deg	

● Typical Electro-Optical Characteristics Curves

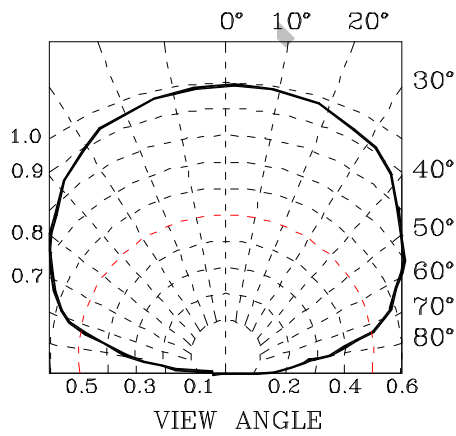
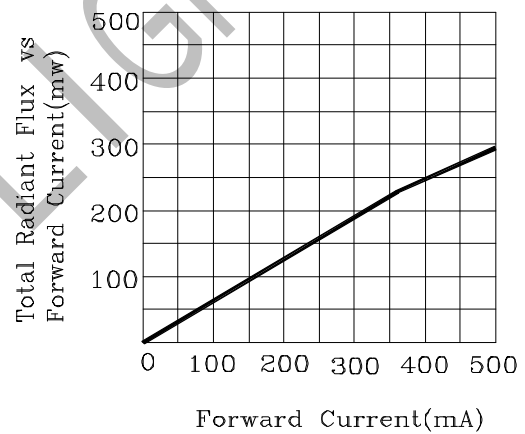
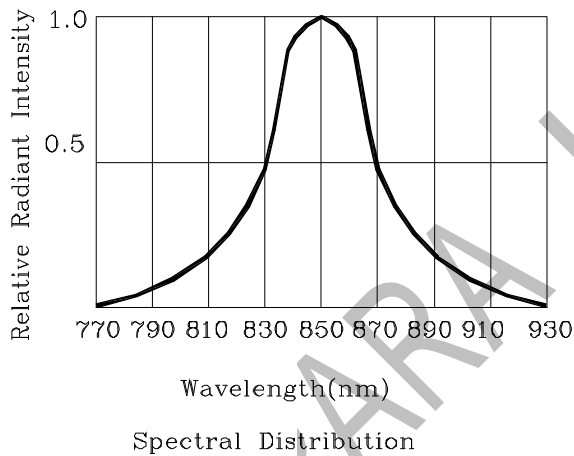
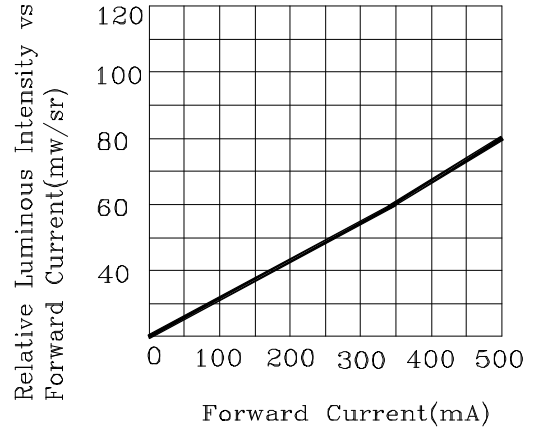
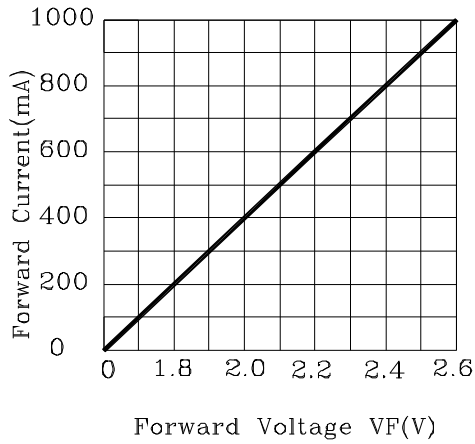

(25°C Ambient Temperature Unless Otherwise Noted)

**1. Reel Dimensions**

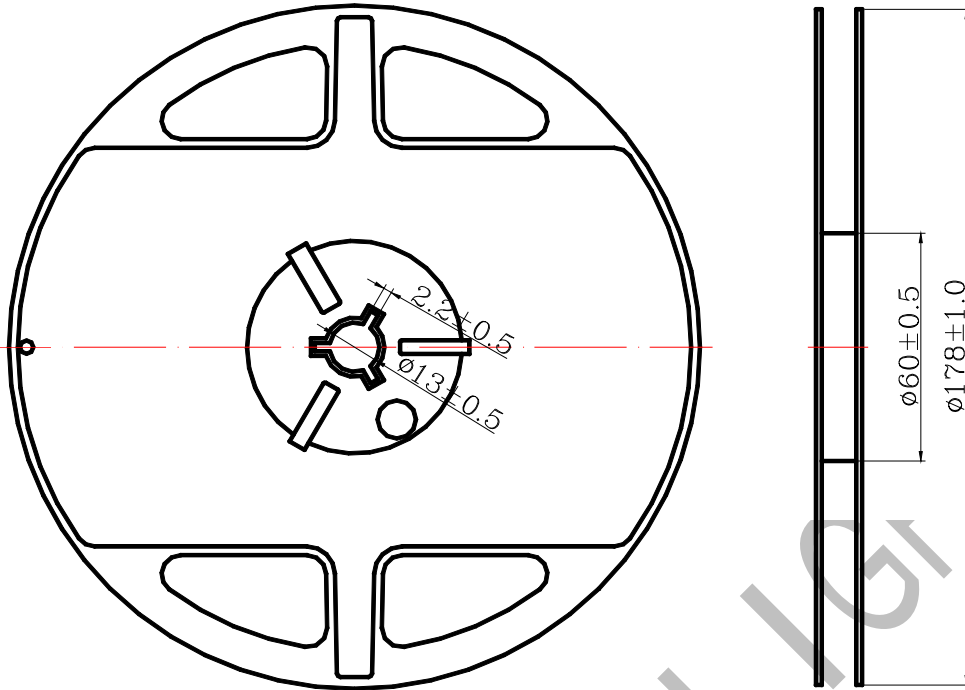

Notes:

- 2. Taping Quantity : 1000pcs max
- 3. The tolerances unless noted is  $\pm 0.1\text{mm}$ , Angle  $\pm 0.5^\circ$  , Unit: mm.

**4. Package Dimensions Of Tape And Reel**

Item	Spec
W	12.00±0.30
P1	8.0±0.10
Do	1.5±0.10
Po	4.00±0.10
P2	2.00±0.10

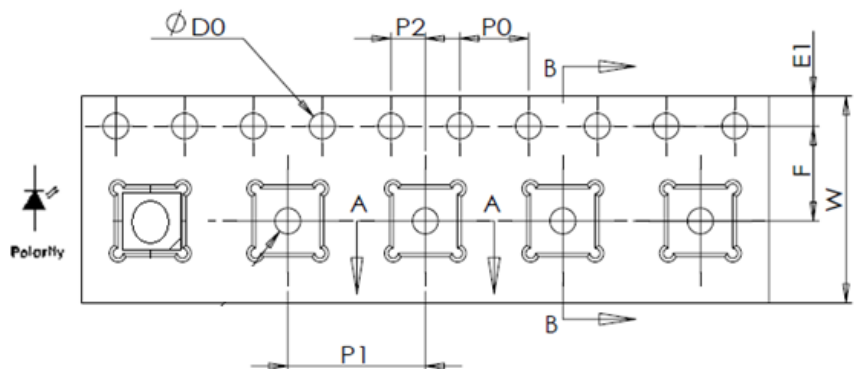

Notes: All dimensions are in millimeters.

**Storage**

Before opening the package:

The IREDS should be kept at 30°C or less and 90%RH or less. The IREDS should be used within a

year. When storing the IREDS, moisture proof packaging with absorbent material (silica gel) is recommended.

After opening the package:

The IREDS should be kept at 30°C or less and 70%RH or less. The IREDS should be soldered within 24 hours (1days) after opening the package. If unused IREDS remain, they should be stored in moisture proof packages, such as sealed containers with packages of moisture absorbent material (silica gel). It's also recommended to return the IREDS to the original moisture proof bag and to reseal the moisture proof bag again.

\*If the moisture absorbent material (silica gel) has faded away or the IREDS have exceeded the storage time, baking treatment should be performed using the following condition.

Baking treatment: more than 24 hours at 65+/-5°C.

**Moisture Proof Package**

\*When moisture is absorbed into the SMT package it may vaporize and expand during soldering. There is a possibility that this can cause exfoliation of the contacts and damage to the optical characteristics of the IREDS. For this reason, the moisture proof package is used to keep moisture to a minimum in the package.

\*The moisture proof package is made of an aluminum moisture proof bag with a zipper. A package of a moisture absorbent material (silica gel) is inserted into the aluminum moisture proof bag. The silica gel changes its color from blue to pink as it absorbs moisture.

**Heat treatment**

\*Thermal design of the end product is of paramount importance. Please consider the heat generation of the IRED when making the system design. The coefficient of temperature increase per input electric power is affected by the thermal resistance of the circuit board and density of IRED placement on the board, as well as other components. It is necessary to avoid intense heat generation and operate within the maximum ratings given in this specification.

\*The operating current should be decided after considering the ambient maximum temperature of IREDS.

**Clean**

If cleaning is required, use a clean, soft cloth to lightly wipe off foreign objects with alcohol, and do not use detergents such as acetone to avoid possible corrosion damage.

**Electrical precautions**

1. The LED does not allow reverse drive.
2. The current limiting measure is necessary, otherwise a slight voltage change will result in a large current change that may cause the LED to fail.
3. Under the premise that the luminous amount meets the requirements, it is recommended to use a drive current below the rated current, which is conducive to improving the reliability of the product.

**Anti-static measures**

LED is an electrostatic sensitive device, in the process of preservation, use to take anti-static measures. Static electricity and surges can cause changes in product characteristics, such as lower forward voltages, which can be severe and even damage the product. Therefore, for the entire process (production, testing, packaging, etc.) and LED direct contact with the staff should do a good job to prevent and eliminate static electrical measures. All relevant equipment and machines should be properly grounded. Ground AC resistance is less than 1.0 ohms, and the workbench requires a table mat with a surface resistor of 10<sup>6</sup>-10<sup>9</sup> ohms. Ion fans must also be installed in environments and devices that are prone to static electricity. During the operation, the operator should use anti-static bracelets, anti-static mats, anti-static work clothes, work shoes, gloves, static capacitors and so on.

**Electric soldering iron**

It is recommended to use an anti-static electric iron at a tip temperature of no more than 350 °C and less than 3 seconds at each solder. The power of the electric soldering iron should be less than 60W. Two electrode pins are welded separately, after more than 2 seconds after each solder. Do not exert pressure on the lens when soldering. LED problems usually start from solder. Therefore, it is necessary to work carefully as required.

**■Surface Mounting Condition**

In automatic mounting of the SMD IREDS on printed circuit boards, any bending , expanding and pulling forces or shock against the SMD IREDS shall be kept min. to prevent them from electrical failures and mechanical damages of the devices .

**Soldering Reflow**

Soldering of the SMD IREDS shall conform to the soldering condition in the individual specifications.

SMD IREDS are designed for Reflow Soldering.

In the reflow soldering , too high temperature and too large temperature gradient such as rapid heating / cooling may cause electrical & optical failure and damages of the devices . Solidlite can not guarantee the IRED after they have been assembled using the solder dipping method.

Suggest Pb-Free IR Reflow Soldering Profile Condition:

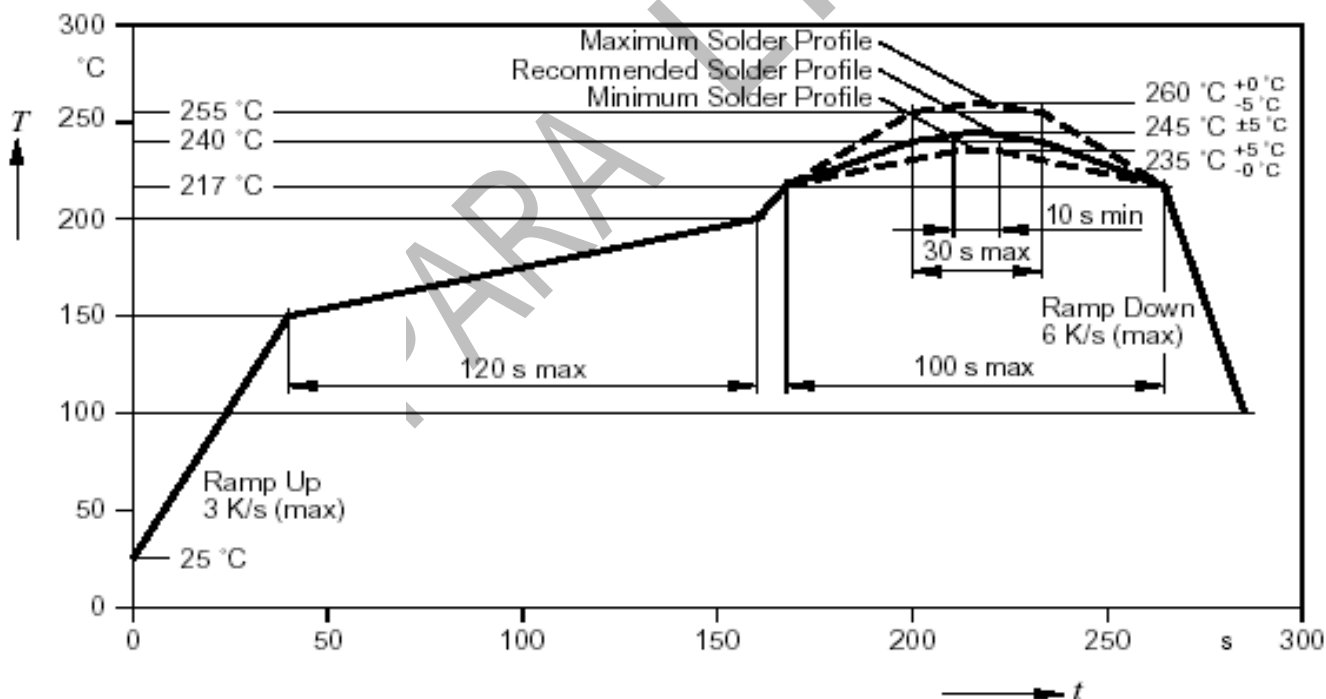



**Bin Code list**

Forward Voltage (VF), Unit:v@350mA		
Bin Code	Min	Max
A2	1.6	1.8
B1	1.8	2.0
B2	2.0	2.2
C1	2.2	2.4
C2	2.4	2.6

Tolerance of each bin are  $\pm 0.1$  Volt

Total Radiant Flux , Unit:mW@350mA		
Bin Code	Min	Max
10	165	210
11	210	255
12	255	300

Tolerance of each bin are  $\pm 15\%$

● PART NO. SYSTEM :

L - T 3535 IR4 C T - X - X - X - X

B :Black Face  
W:white Face

E : EMC  
P: PPA/PCT  
C: ceramics

P: Viewing Angle 120  
Y: Viewing Angle 150

Dice Size:  
N: 28mil R:35mil  
U:42mil K:20mil

T : Taping for 7 inch reel  
TC : Taping for 13 inch reel

Lens color  
C : Water Clear  
W : White Diffused  
T : Color Transparent  
D : Color Diffused

LB : InGaN ITO rough 470nm Blue  
LG : InGaN ITO rough520nm Green  
W : InGaN + YAG White color  
IR1:940nm SURFACE MOUNT DEVICE LED  
IR4:850nm SURFACE MOUNT DEVICE LED

3535 3.5\*3.5mm

C : PCB Top View Type  
T :PLCC Top View Type  
S : Side View Type